

# SMART Digital S

DIGITAL DOSING up to 30 l/h

Next generation DDA-C, DDC, DDE



<b>1. General data</b>	<b>4</b>
Performance range	4
Features at a glance	5
<b>2. Identification</b>	<b>8</b>
Type key	8
<b>3. Functions</b>	<b>10</b>
Overview of functions	10
Functional description	11
Control cube DDA-C and DDC	12
Operating elements, DDE	13
Menu	14
Operation modes	16
Functions	20
New functions in the DDA-C	27
Wiring diagram, DDA-C	28
Wiring diagram, DDC	30
Wiring diagram, DDE-PR, -P	31
<b>4. Construction</b>	<b>32</b>
DDA-C and DDC	32
DDE	34
<b>5. Dimensions</b>	<b>36</b>
Dimensions, SMART S DDA-C	36
Dimensions, SMART S DDC	37
Dimensions, SMART S DDE	38
<b>6. Technical data</b>	<b>39</b>
Technical data, SMART S DDA-C	39
Technical data, SMART S DDC	41
Technical data, SMART S DDE	43
Technical data for CIP (Clean-In-Place) applications	44
<b>7. Pump selection</b>	<b>45</b>
DDA-C, standard range	45
DDC, standard range	46
DDE, standard range	47
DDA-C, DDC, DDE, non-standard range	48
<b>8. Accessories for small dosing pumps up to 60 l/h</b>	<b>50</b>
Accessories overview	50
Installation kits for dosing pumps	52
Cables and plugs	54
Hoses	54
Foot valves FV	56
Rigid suction lances RSL	59
Injection units	64
Multi-function valves, pressure-relief valves, pressure-loading valves	68
Pump connection kits and inlay kits	72
Adapters	74
Dosing tanks	77
Water meter	87
<b>9. Pumped liquids</b>	<b>88</b>

<b>10. Grundfos Product Center</b> .....	<b>90</b>
<b>11. Document quality feedback</b> .....	<b>91</b>

# 1. General data

## Performance range

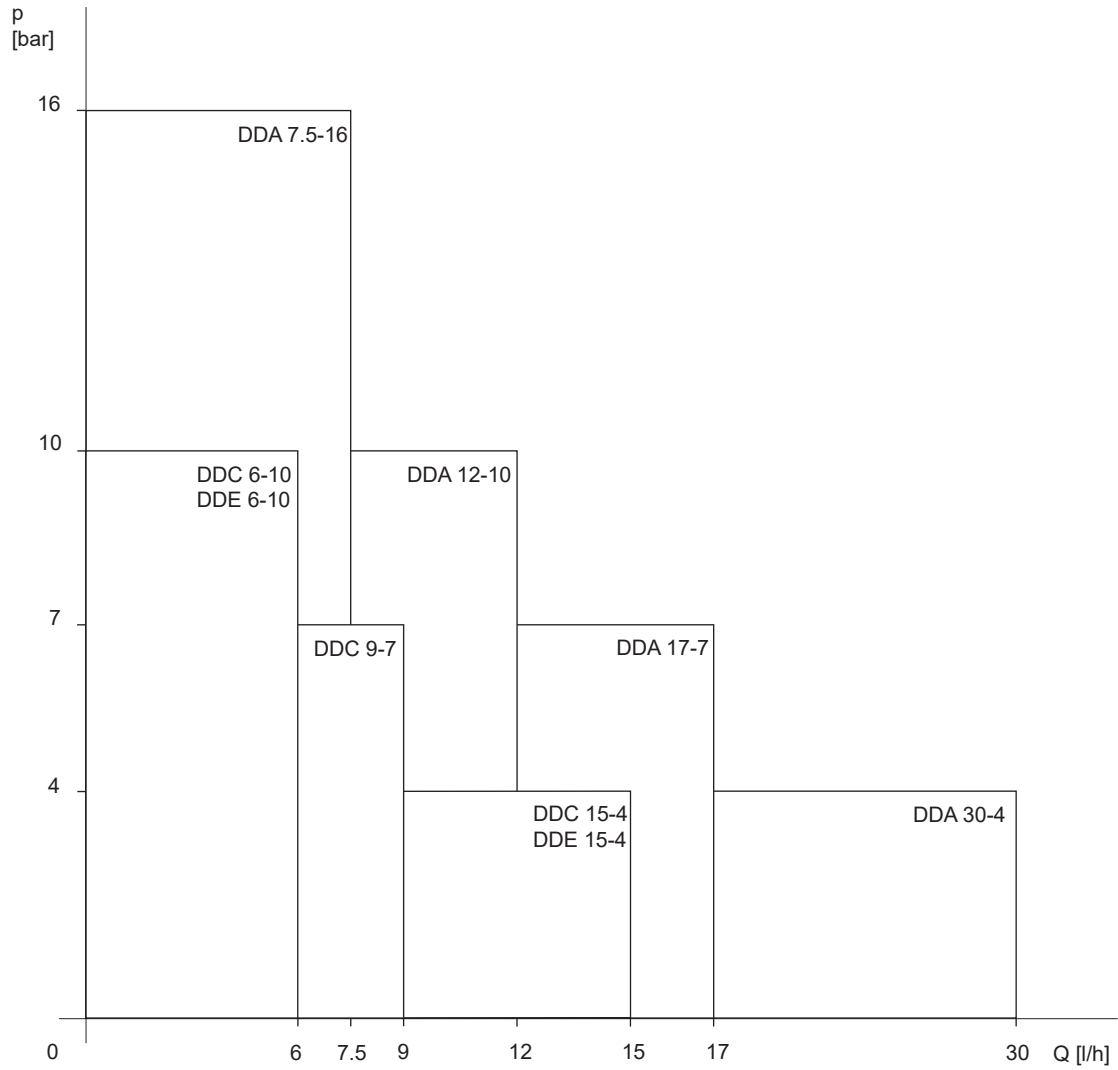

TM041480

*Performance range*

## Features at a glance



GR-107867\_SMART\_DIGITAL\_S\_FAMILY

DDA-C, DDC, DDE

### Digital Dosing™

The SMART Digital S generation DDA-C, DDC and DDE with powerful variable-speed stepper motor brings state-of-the-art technology to perfection. Combined expert knowledge and patented solutions set future standards. Traditional technologies, such as stroke length or stroke frequency adjustment with synchronous motor or solenoid drive, become a thing of the past.

#### Unique flexibility with only a few variants

The included click-stop mounting plate makes the pump more flexible. Three different positions are possible without using any additional accessories, such as wall brackets. Service and pump exchange can now be done easily by clicking the pump in and out of the mounting plate.

The control cube on the DDA-C and DDC pump can be lifted and turned easily into three different positions: front, left or right.



TM067120

Modularity of the control cube, DDA-C



TM041662

### Modularity of the control cube, DDC

A turn-down ratio of up to 1:3000, a wide supply voltage range (100-240 V; 50/60 Hz), combined connection sets and other features reduce the models and variants to a minimum.

### Precise and easy setting / usability and interaction

The operator can easily install the pump and set it to discharge exactly the quantity of dosing liquid required for the application. DDA-C has integrated bluetooth and can be used with the Grundfos GO application. In the display, the setting of the pump is read out directly, the flow is shown in ml/h, l/h, or gph.

The click wheel (turn-and-push) and the graphical LC display with plain-text menu in more than 25 languages make commissioning and operation intuitive. As the LCD is backlit in different colours, the pump status can be seen from a distance (traffic-light concept).

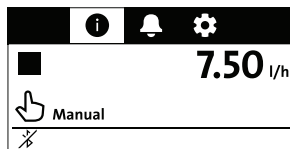

TM088254

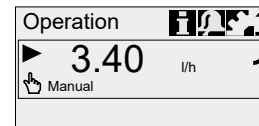

TM048170

Display, DDA-C

Display DDC

Thanks to a variety of operation modes, signal inputs and outputs, the pump can easily be integrated into every process.

### Advanced process reliability

An intelligent drive and microprocessor control ensures that dosing is performed precisely and with low pulsation, even if the pump is dosing high-viscosity or degassing liquids. Malfunctions, caused by, for example, air bubbles, are detected quickly by the maintenance-free FlowControl system, and then displayed in the alarm menu.

The AutoFlowAdapt function automatically adjusts the pump according to the process conditions, such as varying backpressure. The integrated flow measurement makes additional monitoring and control equipment redundant.

### Designed to save costs

In general, the investment for a dosing pump installation is low compared to its life cycle costs, including the cost of the chemicals. The following features make the SMART Digital S DDA-C, DDC and DDE pumps contribute to low life-cycle costs:

- no underdosing or overdosing due to high dosing accuracy and FlowControl
- longer maintenance intervals due to the universal chemical resistance of the full-PTFE diaphragm
- reduced energy consumption due to the state-of-the-art drive technology.

### Three application-oriented type ranges

DDA-C is a high-end pump range for extended flow and pressure ranges with sensor-based FlowControl and measurement functions for challenging industrial applications such as the following:

- process water
- food and beverage
- ultrafiltration and reverse osmosis
- pulp and paper
- boiler feed water
- CIP (Cleaning-In-Place).

DDC is a user-friendly pump range with standard inputs and outputs for common applications like the following:

- drinking water
- waste water

- swimming pool water
- cooling tower
- chemical industry.

DDE is a low-budget pump range with basic functions including manual operation or control via PLC for OEM applications, for example:

- car wash
- irrigation.

## 2. Identification

### Type key

The type key is used to identify the precise pump and is not used for configuration purposes.

<b>Type</b>	
DDA 7.5-16 AR-C-PP/V/C-F-31U2U2FG	
DDA	
DDC	
DDE	
<b>Nominal dosing capacity [l/h]</b>	
DDA 7.5-16 AR-C-PP/V/C-F-31U2U2FG	
<b>Max. pressure [bar]</b>	
DDA 7.5-16 AR-C-PP/V/C-F-31U2U2FG	
<b>Control variant</b>	
DDA 7.5-16 AR-C-PP/V/C-F-31U2U2FG	
B	Basic (only DDE)
P	B with pulse mode (DDE)
PR	P with relay output (DDE)
A	Standard (DDC)
AR	A with alarm relay and analog input (DDC)
AR-C	Standard with embedded connectivity (DDA-C)
FCM-C	AR-C with FlowControl measurement (DDA-C)
<b>Dosing head variant</b>	
DDA 7.5-16 AR-C-PP/V/C-F-31U2U2FG	
PP	Polypropylene
PVC	PVC (polyvinyl chloride, only up to 10 bar)
PV	Polyvinylidene fluoride (PVDF)
SS	Stainless steel 1.4435
<b>Gasket material</b>	
DDA 7.5-16 AR-C-PP/V/C-F-31U2U2FG	
E	EPDM
V	FKM
T	PTFE
<b>Valve ball material</b>	
DDA 7.5-16 AR-C-PP/V/C-F-31U2U2FG	
SS	Stainless steel 1.4401
C	Ceramic
<b>Control Cube</b>	
DDA 7.5-16 AR-C-PP/V/C-F-31U2U2FG	
F	Front-mounted (change to left or right is possible)
X	No control cube
<b>Supply voltage</b>	
DDA 7.5-16 AR-C-PP/V/C-F-31U2U2FG	
3	1 × 100-240 V, 50/60 Hz
<b>Valve type</b>	
DDA 7.5-16 AR-C-PP/V/C-F-31U2U2FG	

<b>Valve type</b>	
1	Standard (not spring-loaded)
2	Spring-loaded (HV version)

<b>Connection, suction/discharge</b>	
DDA 7.5-16 AR-C-PP/V/C-F-31U2U2FG	
U2U2	Hose, 4/6 mm, 6/9 mm, 6/12 mm, 9/12 mm
U7U7	Hose 0.17" × 1/4"; 1/4" × 3/8"; 3/8" × 1/2"
AA	Threaded Rp 1/4, female (stainless steel)
VV	Threaded 1/4 NPT, female (stainless steel)
XX	No connection

<b>Installation set <sup>1)</sup></b>	
I001	Hose, 4/6 mm (up to 7.5 l/h, 13 bar)
I002	Hose, 9/12 mm (up to 60 l/h, 9 bar)
I003	Hose, 0.17" × 1/4" (up to 7.5 l/h, 13 bar)
I004	Hose, 3/8" × 1/2" (up to 60 l/h, 10 bar)

<sup>1)</sup> Including: 2 pump connections, foot valve, injection unit, 6 m PE discharge hose, 2 m PVC suction hose, 2 m PVC de-aeration hose (4/6 mm)

<b>Power plug</b>	
DDA 7.5-16 AR-C-PP/V/C-F-31U2U2EG	
F	EU (Schuko)
B	USA, Canada
G	UK
I	Australia, New Zealand, Taiwan
E	Switzerland
J	Japan
L	Argentina
N	Brazil

<b>Pump design</b>	
G	Grundfos

## 3. Functions

### Overview of functions

Control variant:	DDA		DDC		DDE		
	FCM-C	AR-C	AR	A	PR	P	B
General							
Digital Dosing: Internal stroke speed and frequency control	•	•	•	•	•	•	•
Mounting plate (basic/wall mounting)	•	•	•	•	•	•	•
Control panel, see section Control cube DDA-C and DDC							
Control cube mountable in three positions: front, left, right	•	•	•	•			
Control panel position: front-fitted					•	•	•
Transparent protective cover for control elements	•	•	•	•			
Capacity setting in millilitres, litres or US-gallons	•	•	•	•			
Graphical display with background light in four colours for status indication: white, green, yellow, red	•	•	•	•			
Plain-text menu in different languages	•	•	•	•			
Turn-and-push knob (click wheel) for easy navigation	•	•	•	•			
Capacity adjustment knob (0.1 - 100 %)					•	•	•
Start/Stop key	•	•	•	•			
100 % key (de-aeration)	•	•	•	•	•	•	
Operation mode switch (manual/pulse)					•	•	
Operation modes, see section on operation modes							
Manual speed control	•	•	•	•	•	•	•
Pulse control in ml/pulse	•	•	•	•			
Pulse control (1:n)					•	•	
Analog control 0/4-20 mA	•	•	•				
Batch control (pulse-based)	•	•					
Dosing timer cycle	•	•					
Dosing timer week	•	•					
Fieldbus control	•	•					
Functions, see section on functions							
Auto de-aeration also during pump standby	•	•					
FlowControl system with selective fault diagnosis	•						
Pressure monitoring (min/max)	•						
Flow measurement	•						
AutoFlowAdapt	•						
SlowMode (anti-cavitation)	•	•	•	•			
Calibration mode	•	•	•	•			
Scaling of analog input	•	•					
Service information display	•	•	•	•			
Relay setting: alarm, warning, stroke signal, pump dosing, pulse input <sup>2)</sup>	•	•	•		•		
Relay setting (additionally): timer cycle, timer week	•	•					
Inputs/outputs, see section Level control							
Input for external stop	•	•	•	•	•	•	
Input for pulse control	•	•	•	•	•	•	
Input for analog 0/4-20 mA control	•	•	•				
Input for low-level signal	•	•	•	•	•	•	
Input for empty tank signal	•	•	•	•	•	•	
Output relay (2 relays)	•	•	•		•		
Output analog 0/4-20 mA	•	•					
Input/Output for GENibus	•	•					
Input/Output for CIM modules (for example, Profinet, Profibus)	•	•					
Input/Output for Modbus TCP and Modbus RTU	•	•					
Bluetooth communication	•	•					

Statistics on fault detection	•	•		
Store/recall settings	•	•	•	•
Parameter transfer from one pump to another	•	•		
Max.capacity/max. flow	•	•		
Settings and key lock	•	•	•	•
Stop after power failure	•	•		
ConditionCheck	•			
Multi parameter display (dashboard)	•	•		
Device name	•	•		
Software update	•	•		
Analog input/output calibration	•	•		

2) DDE-PR: relay 1: alarm; relay 2: low-level signal, stroke signal, pulse input

**Related information**

[Control cube DDA-C and DDC](#)

[Manual control](#)

[SlowMode](#)

[Level control](#)

**Functional description**

The electronically controlled variable-speed motor (stepper motor) of the DDA-C, DDC and DDE pumps provides optimum control of the stroke speed. The duration of each discharge stroke varies according to the capacity set, resulting in optimum discharge flow in any operating situation, while the duration of each suction stroke is constant. See the figure below.

The advantages are as follows:

- The pump always operates at full stroke length, irrespective of the capacity set, which ensures optimum accuracy, priming and suction.
- A capacity range of up to 1:3000 (turn-down ratio) results in less variants and spare parts.
- Smooth and continuous dosing ensures an optimum mixing ratio at the injection point without static mixers.
- There is a significant reduction of pressure peaks, preventing mechanical stress on wearing parts, such as diaphragm, tubes, connections, resulting in extended maintenance intervals.
- The installation is less affected by long suction and discharge lines.
- Dosing of high-viscosity and degassing liquids (SlowMode) is easier.

The optimum dosing control shown below applies to any operation mode.

**Relation between stroke-frequency adjustment and capacity**

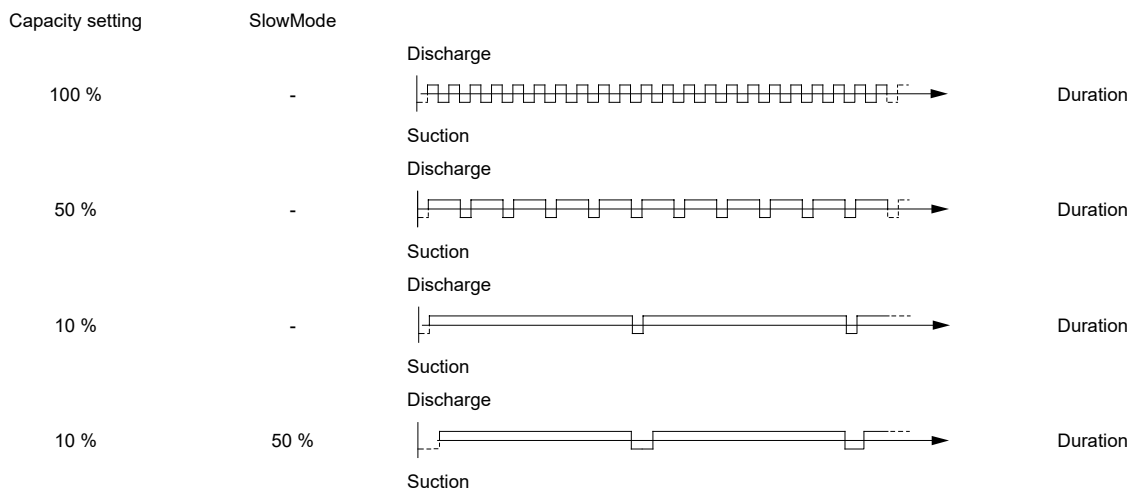

Extended suction stroke (SlowMode)

## Control cube DDA-C and DDC

DDA-C and DDC pumps are supplied with front-mounted control cube. The position of the control cube can easily be changed by unfastening two screws, lifting the cube, turning it to the left or to the right, and fastening the screws again.

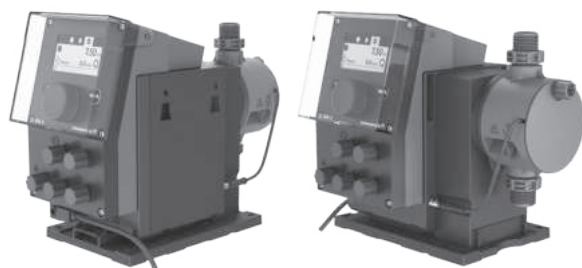

TM088140

Two of three possible control cube positions, DDA-C

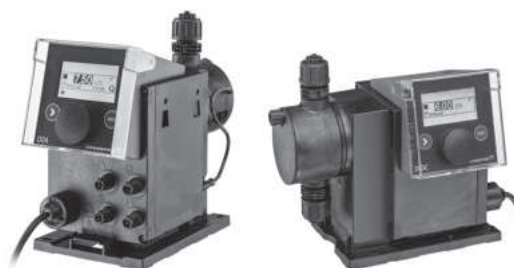

TM069584

Two of three possible control cube positions, DDC

## Operating elements, DDA-C

The user interface of the pump includes a display and operating elements.

If the pump is operated via the **Grundfos GO** app, the operating elements are locked.



TM087635

Pos.	Description
1	Graphical LC display
2	Click wheel
3	Start/Stop key
4	100% key

### Click wheel

The click wheel is used for navigating through the menus, and selecting and confirming settings.

Turning the click wheel clockwise moves the cursor clockwise on the display. Turning the click wheel counter-clockwise moves the cursor counter-clockwise.

If the pump is operated via the **Grundfos GO** app, the click wheel cannot be used for navigating through the menus. To be able to navigate through the menus again, turn the click wheel and disconnect from GO.

### Start/Stop key

The **Start/Stop key** is used for starting and stopping the pump. It can still be used while the pump is operated via the **Grundfos GO** app.

### 100% key

If the 100% key is pressed for less than 1 second, the display returns to the **Idle screen**.

If the 100% key is pressed for longer than 1 second, the pump doses at maximum flow, regardless of the operation mode. The pump continues dosing for 5 seconds while the click wheel can be operated. This is useful for one-handed operation during processes such as start-up or de-aeration.

The 100% key is locked when the pump is operated via the **Grundfos GO** app.

### Operating elements, DDC

The pump operating panel includes a display and operating elements.

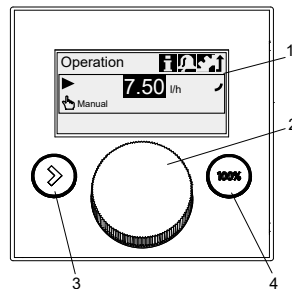

TM041188

Pos.	Description
1	Graphical LC display
2	Click wheel
3	Start/Stop key
4	100% key

#### Click wheel

The click wheel is used for navigating through the menus, and selecting and confirming settings.

Turning the click wheel clockwise moves the cursor clockwise on the display. Turning the click wheel counterclockwise moves the cursor counterclockwise.

#### Start/Stop key

The Start/Stop key is used for starting and stopping the pump.

#### 100% key

The pump doses at maximum flow regardless of the operation mode.

### Operating elements, DDE

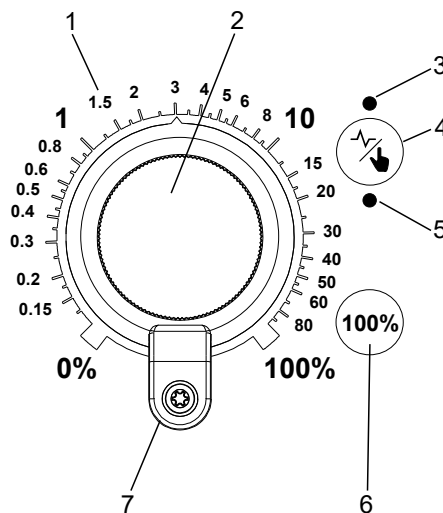

TM041150

Pos.	Description
1	Logarithmic scale
2	Capacity adjusting knob
3	Status LED "Pulse" (only DDE-PR/P control variant)
4	Operation mode key (only DDE-PR/P control variant)
5	Status LED "Manual"
6	100% key (only DDE-PR/P control variant)
7	Mechanical lock

## Menu

The DDA-C and DDC dosing pumps feature a user-friendly plain-text menu. The menu consists of 4 tabs: Operation, Info, Alarm and Setup. During initial start-up, all menu texts appear in English. The menu can be set to other languages.

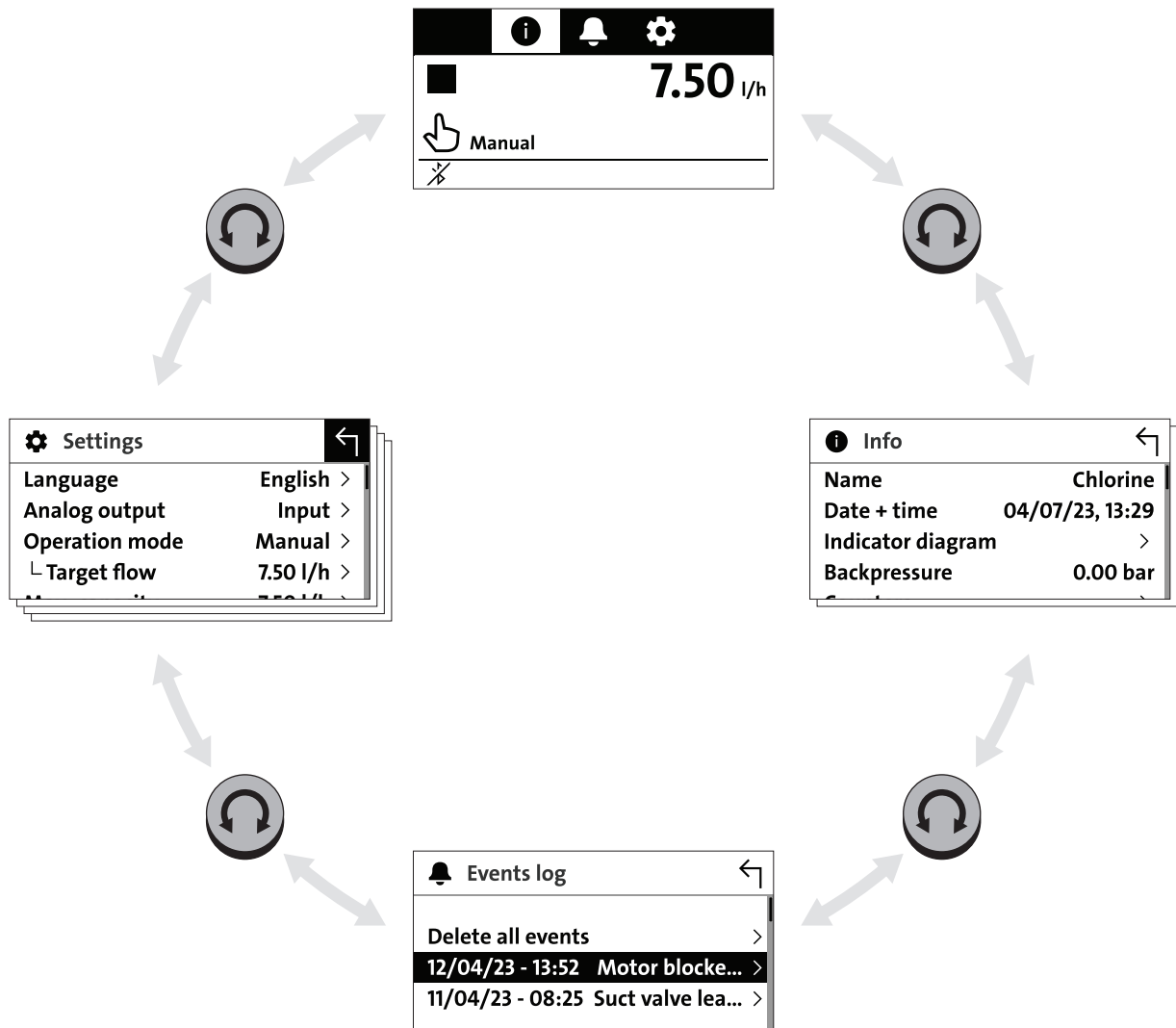

TM087528

Menu overview (example of main menus), DDA-C

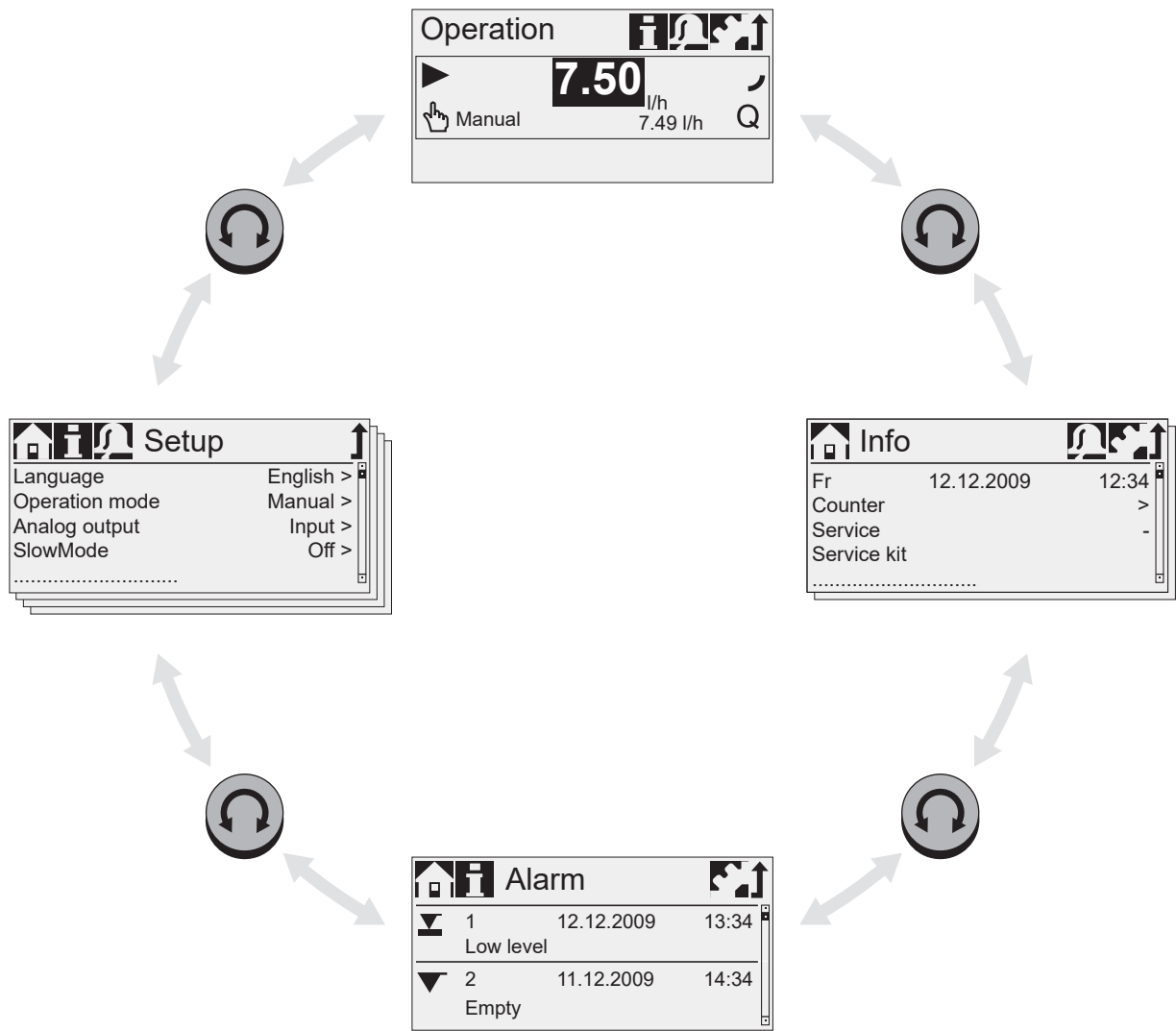

TM088274

*Menu overview (example of main menus), DDC*

The menu text appears in more than 25 languages on a big graphical display, backlit in four different colours according to the traffic light concept.

Display	Fault	Pump status
White	-	Stop Standby
Green	-	Running
Yellow	Warning	Stop Standby Running
Red	Alarm	Stop Standby

## Operation modes

### Manual control

The pump ensures constant dosing according to the quantity set in l/h or ml/h or gph by the click wheel. The pump automatically changes between the measuring units.

#### Setting range

Pump type	Setting range <sup>3)</sup>	
	From [l/h]	To [l/h]
DDA-C 7.5-16	0.0025	7.5
DDA-C 12-10	0.0120	12.0
DDA-C 17-7	0.0170	17.0
DDA-C 30-4	0.0300	30.0
DDC 6-10	0.0060	6.0
DDC 9-7	0.0090	9.0
DDC 15-4	0.0150	15.0
DDE 6-10	0.0060	6.0
DDE 15-4	0.0150	15.0

<sup>3)</sup> When the SlowMode function is enabled, the maximum flow is reduced, see section SlowMode.

### Related information

[SlowMode](#)

### Pulse control

The pump doses in proportion to an external potential-free pulse signal, for example, from a water meter. There is no direct relation between pulses and dosing strokes. The pump automatically calculates its optimal speed to ensure that the required quantity is dosed for each incoming pulse.

*For DDA-C and DDC:*

The quantity to be dosed is set in ml/pulse. The pump adjusts its speed according to two factors:

- the frequency of external pulses
- the set quantity per pulse.

#### Setting range

Pump type	Setting range [ml/pulse]
DDA-C 7.5-16	0.0015 - 14.9
DDA-C 12-10	0.0029 - 29.0
DDA-C 17-7	0.0031 - 31.0
DDA-C 30-4	0.0062 - 62.0
DDC 6-10	0.0016 - 16.2
DDC 9-7	0.0017 - 16.8
DDC 15-4	0.0032 - 31.6

The frequency of external pulses is multiplied by the set quantity. If the product exceeds the maximum flow of the pump, a maximum of 65,000 pulses can be stored for later processing with the Memory pulse function, when activated.

*For DDE-PR, DDE-P control variant:*

The dosing quantity per pulse is adjusted with the adjustment knob according to a scale from 0.1 to 100 % of the stroke volume. The pump adjusts its speed according to two factors:

- the frequency of external pulses
- the set percentage of stroke volume.

#### Setting range, DDE-PR, DDE-P

Pump type	Setting range [ml/pulse]
DDE 6-10	0.0008 - 0.81
DDE 15-4	0.0016 - 1.58

### Analog 0/4-20 mA control

This section applies to the DDA-C and DDC-AR control variant.

The pump ensures dosing according to an external analog signal. The dosed capacity is proportional to the input value in mA.

Operation mode	Input signal	Dosing capacity
4-20	$\leq 4.1$ mA	0 %
	$\geq 19.8$ mA	100 %
0-20	$\leq 0.1$ mA	0 %
	$\geq 19.8$ mA	100 %

The relation of the analog input value and the dosing flow, as shown in the table, can be set in the **Grundfos GO** app in **Advanced settings > Analog input border**.

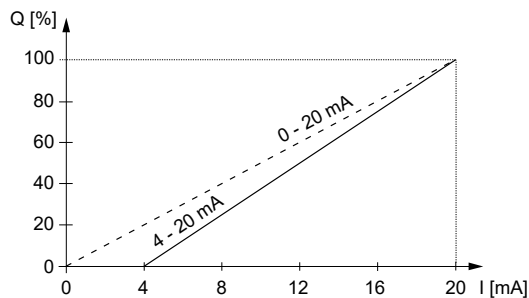

TM041120

#### 0/4-20 mA control

This section applies to the DDA-C.

With the **Analog scaling** function, the curve can be individually drawn between two arbitrary points: A ( $I_1/Q_1$ ) and B ( $I_2/Q_2$ ).

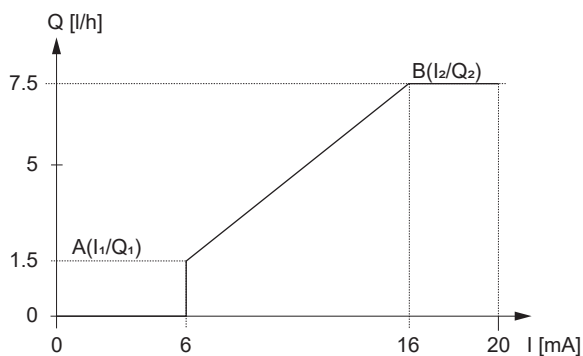

TM087861

#### Analog scaling with positive gradient

Pos.	Description
Q [l/h]	Dosing capacity
I [mA]	Input signal

## Batch

*This section applies to the DDA-C.*

In the Batch mode, the pump doses the set **Batch volume** in the set **Batch duration**. A batch is dosed every time the pump receives an external pulse or the Start/Stop key is pushed. If the pump receives new pulses before a batch is completed, these pulses are ignored.

If **Continue after interrupt** is activated, the pump stops dosing and goes to operating state "Ready" in the event of an interruption (**Alarm**, **External stop**). The remaining **Batch volume** and **Batch duration** are displayed. Once the interruption is resolved, the pump automatically continues dosing the remaining **Batch volume** in the remaining **Batch duration**.

If **Continue after interrupt** is deactivated, the pump stops dosing and the batch is reset in the event of an interruption. The remaining **Batch volume** is displayed. Once the interruption is resolved, the pump waits for the next trigger to restart with a new batch.

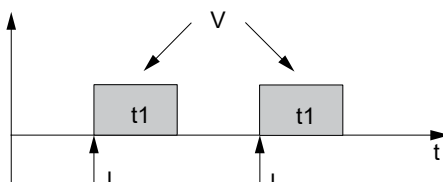

TM041105

Pos.	Description
V	Batch volume
I	Pulse
t	Time
t1	Batch duration

The setting range depends on the pump type. If the **SlowMode** is active, the setting range is reduced.

Type	Setting range per Batch		
	from [ml]	to [l]	Resolution <sup>4)</sup> [ml]
DDA-C 7.5-16	0.74	180	0.0925
DDA-C 12-10	1.45	288	0.1813
DDA-C 17-7	1.55	408	0.1938
DDA-C 30-4	3.10	720	0.3875

4) Dosing quantities with a resolution of up to 1/8 of the dosing stroke volume can be dosed due to digital motor control.

## Timer cycle

*This section applies to the DDA-C.*

In the **Timer cycle** mode, the pump doses the set **Batch volume** in regular cycles. A cycle starts after a **Start delay**.

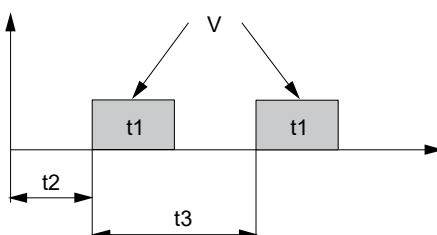

TM041107

Pos.	Description
V	Batch volume
t1	Batch duration
t2	Start delay
t3	Cycle time

In the event of an interruption due to **Alarm** or **External stop**, the pump stops dosing and goes to operating state "Ready" while the **Timer cycle** continues to run. The remaining **Batch volume** and **Batch duration** are displayed. Once the interruption is resolved, the pump automatically continues dosing according to the actual timeline position.

In the event of a power interruption, the pump automatically starts a completely new **Timer cycle**, which begins with a **Start delay** as soon as the power is restored. If the pump is stopped, the **Timer cycle** is lost. A new **Timer cycle** is started when the pump is started.

**Setting range**

The batch volume setting range corresponds to the pulse-based batch control setting range.

**Timer week**

*This section applies to the DDA-C.*

In this operation mode, up to 16 dosing procedures can be defined for a week. These dosing procedures may take place regularly on one or several week days. For the **Batch volume** setting range, see section **Batch**.

Each dosing procedure consists of the following:

- **Weekly schedule**
- **Start time**
- **Batch volume**
- **Batch duration**
- **Active: On/Off.**

In case several procedures overlap, the procedure with the highest flow rate has the highest priority. Batch dosing stops during any interrupt, for example, power supply failure or external stop, while the time continues running in the background (real-time clock). After the interrupt ends, batch dosing proceeds according to the current status in the timeline.

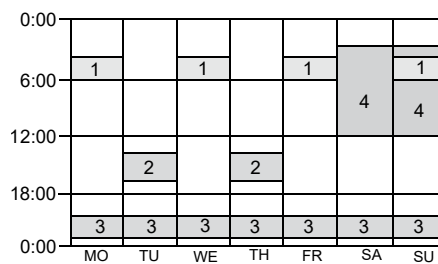

TM041108

*Example of a Weekly schedule*

**Related information**

[Batch](#)

## Functions

### SlowMode

*This section applies to the DDA-C and DDC.*

When the **SlowMode** function (anti-cavitation) is selected, the pump extends and smooths its suction stroke. This results in a softer suction stroke.

The **SlowMode** function is used in the following situations:

- when pumping high-viscosity liquids
- when pumping degassing liquids
- when the suction line is long
- when the suction lift is high.

Depending on the application, the motor speed during the suction stroke can be reduced individually to approximately 50 % or 25 % of the normal motor speed.

The maximum pump capacity is reduced accordingly. See section Functional description for further details.

#### Related information

[Functional description](#)

### Auto deaeration

*This section applies to DDA-C.*

If degassing media are dosed, air pockets can form in the dosing head during breaks in dosing. As a result, it is possible that no medium is dosed when the pump is restarted. The **Auto deaeration** function performs pump de-aeration automatically at regular intervals. Software-controlled diaphragm movements make the air bubbles rise and collect at the discharge valve so that they can be removed on the next dosing stroke.

The **Auto deaeration** function operates under the following conditions:

- if the pump is not in operating state "Stop"
- if no alarm is active
- during breaks in dosing, for example, **External stop** or no incoming pulses.

The **Auto deaeration** function can be activated or deactivated in the **Settings** menu.

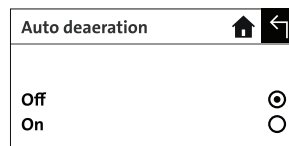

The diaphragm movements can displace small volumes of dosing liquid into the discharge line. This is virtually impossible when dosing highly degassing media.

### Calibration

*This section applies to the DDA-C and DDC.*

The pump is calibrated in the factory at the nominal pressure of the respective pump type. For the maximum pressure, see section Technical data for DDA-C and DDC. After start-up, the dosing pump can be calibrated for the actual installation to ensure that the displayed value (ml, l or gph) is correct. A calibration program in the setup menu facilitates this process. The **AutoFlowAdapt** function keeps the dosing precision (DDA FCM-C control variant), even if the backpressure changes. For the description of the **AutoFlowAdapt** function, see section **AutoFlowAdapt**.

#### Related information

[AutoFlowAdapt](#)

[Technical data, SMART S DDA-C](#)

[Technical data, SMART S DDC](#)

### External stop

*This section applies to the DDA-C, DDC, DDE-PR and DDE-P.*

With the **External stop** function, the pump can be stopped from a remote place via an external contact. It is not recommended to switch on and off the power supply as it was usual when working with a conventional dosing pump. When working with microprocessor-controlled digital dosing pumps, the **External stop** signal has to be used to keep the optimal dosing precision and prevent damages to the electronics.

When activating the **External stop** signal, the pump changes from running to standby. The operation display shows an activated **External stop**. The signal input can be set to **Normally open (NO)**(default) or **Normally closed (NC)** contact.

## Counters

*This section applies to the DDA-C and DDC.*

The pump displays resettable and non-resettable counters in the info menu tab.

Counter	Description	Resettable
Trip volume	Volume dosed from a container in litres or US gallons.	Yes
Total volume (DDA-C)	Accumulated dosed quantity in litres or US gallons	No
Operating hours	Accumulated number of operating hours (power-on)	No
Motor runtime	Accumulated number of motor runtime hours	No
Strokes	Accumulated number of dosing strokes	No
Power on/off	Accumulated number of times the mains supply has been switched on	No

## Service display

*This section applies to the DDA-C and DDC.*

Due to the optimised construction and the smooth digital dosing principle, the service periods are more than twice as long as those of conventional pumps. However, the wear parts have to be exchanged at regular intervals to keep the dosing precision and process reliability at a high level. The service display in the pump shows when service of the wear parts is required. The displayed service kit product number makes service more convenient. The following information is presented in the Info display:

Display	Description
Service	-
	Soon
	Now
Service kit	8-digit Grundfos product number
Reset service system	After performing the service, reset the system.

The following service messages appear, depending on what happens first:



Display	Motor runtime [h]	Regular intervals [months]
Service soon	7,500	23
Service now	8,000	24

In case of difficult liquids, the service intervals may be shorter and service has to be performed earlier.

## Level control

*This section applies to the DDA-C, DDC, DDE-PR and DDE-P.*

The pump can be connected to a dual level control unit for monitoring the chemical level in the tank. The pump can react to two level signals:

Level sensors	Pump reaction <sup>5)</sup>	
	DDA-C, DDC	DDE-PR, DDE-P
 Low-level signal	The display is yellow (Warning). The Low-level signal is flashing. The pump continues running.	The LED lights up in yellow. The pump continues running.
 Empty tank signal	The display is red (Alarm). The Empty tank signal is flashing. The pump stops.	The LED lights up in red. The pump stops.

<sup>5)</sup> Depending on the pump model and settings, the relay outputs can be activated, see section Relay output.

## Related information

[Relay output](#)

## Relay output

*This section applies to DDA-C, DDC-AR and DDE-PR.*

The pump can activate 2 external signals by built-in relays switched via internal potential-free contacts. Depending on the process control requirements, the following relay output settings can be selected:

*For the DDA-C and DDC-AR:*

Signal		Description
Relay 1	Relay 2	
Alarm <sup>6)</sup>	Alarm	The display is red, the pump stops (for example Empty signal).
Warning <sup>6)</sup>	Warning	The display is yellow, the pump is running (for example Low-level signal).
Alarms+Warnings	Alarms+Warnings	See the descriptions above.
Stroke signal	Stroke signal	It signals each full stroke.
Pump dosing	Pump dosing <sup>6)</sup>	The pump is running and dosing.
Pulse input	Pulse input	It signals each incoming pulse from pulse input.
Bus control	Bus control	It is activated by a command in the bus communication. See section Communication (only DDA-C).
	Timer cycle	The timer can be set in menu: on-time, cycle-time, start delay (only DDA-C).
	Timer week	The timer can be set in menu: procedure, on-time, start time and weekdays (only DDA-C).
Contact type		
NO <sup>6)</sup>	NO <sup>6)</sup>	Normally Open Contact
NC	NC	Normally Closed Contact

<sup>6)</sup> Default setting

*For the DDE-PR control variant:*

Signal		Description
Relay 1	Relay 2	
Alarm <sup>7)</sup>		It signals empty tank or blocked motor.
	Low level <sup>7)</sup>	The level is low in the tank.
	Stroke signal	It signals each full stroke.
	Pulse input	It signals each incoming pulse from pulse input.
Contact type		
NO <sup>7)</sup>	NO <sup>7)</sup>	Normally Open Contact
NC	NC	Normally Closed Contact

<sup>7)</sup> Default setting

## Related information

[Communication](#)

## Analog output

*This section applies to the DDA-C.*

In addition to the analog input (operation mode: analog 0/4-20 mA), the pump is also equipped with an analog 0/4-20 mA output signal. Depending on the process control requirements, the following analog output settings are available:

Setting	Description of analog output signal	Control variant	
		FCM-C	AR-C
Output = Input	Analog feedback signal (not for master-slave application): the analog input signal is mapped 1:1 to the analog output.	X	X
Actual flow	Flow is measured in the dosing head. (See section Flow measurement.)	X	X <sup>8)</sup>
Backpressure	Backpressure is measured in the dosing head. (See section Pressure monitoring.)	X	
Bus control	It is set by a command in the bus communication. (See section Communication.)	X	X

<sup>8)</sup> Output signal is calculated based on motor speed and pump status (target flow rate).

The analog input and output are calibrated in the factory. As a rule, they do not need to be recalibrated. If necessary, it is possible to calibrate analog input and output via **Advanced settings** in the **Grundfos GO** application.

**Related information**[FlowControl](#)[Pressure monitoring](#)[Communication](#)**Key lock and mechanical lock***For the DDA-C and the DDC:*

To protect the pump from maloperation, a key lock can be set by entering a 4-digit PIN code. When the pump is locked, it is still possible to navigate through the menus Alarm and Info, and to acknowledge alarms. For the DDA-C, it is also possible to acknowledge alarms in the **Events log** menu, and check the settings in the **Settings** menu.

Two levels of protection are available:

- **Settings:** the start/stop key and 100% key are still available.
- **Settings + keys:** the start/stop key and 100% key are also locked.

For temporary (2 minutes) or final deactivation, the 4-digit preset PIN code has to be entered again.

*For the DDE:*

The adjustment knob can be locked with a locking screw to fix the current setting.

**Basic settings***This section applies to the DDA-C and DDC.**For the DDA-C:*

With **Factory reset**, the pump can be reset to the default settings. In addition, with **Store settings**, the current configuration of the pump is stored and can be restored later by **Recall settings**. The latest saved configuration is stored in the memory.

In the **Grundfos GO** app, the following options are available:

- **Store settings in GO:** The current pump configuration is saved to the memory in Grundfos GO.
- **Store settings on pump:** The current pump configuration is saved to the memory of the pump.
- **Restore settings:** All settings are reset to the stored settings.
- **Factory reset:** All settings are reset to the factory settings.

*For the DDC:*

With load factory settings, the pump can be reset to the default settings. In addition, with save customer settings, the current configuration of the pump is stored and can be restored later by load customer settings. The latest saved configuration is stored in the memory.

**Units***This section applies to the DDA-C and DDC.*

It is possible to select metric units (litre/millilitre/bar) or US units (US gallons/psi). Depending on the operation mode and menu, the following units are displayed:

Operation mode/Function	Metric units	US units
Manual control	ml/h or l/h	gph
Pulse control	ml/pulse	ml/pulse
Analog 0/4-20 mA control	ml/h or l/h	gph
Batch control (pulse- or timer-based)	ml or l	gal
Calibration	ml	ml or gal
Volume counter	l	gal
Pressure monitoring	bar	psi

## Additional display

*This section applies to the DDC.*

The additional display provides additional information about the current pump status. The value is displayed with the corresponding symbol.

In **Pulse** mode, the target flow information can be displayed, for example,  $Q = 1.28 \text{ l/h}$ .

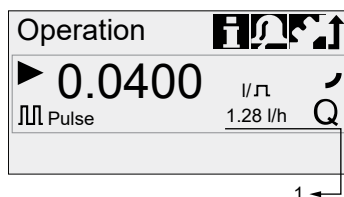

TM048167

Pos.	Description
1	Additional display

The additional display can be set as follows:

Setting	Description
Default display	Target flow ( <b>Pulse</b> )
	Input current ( <b>Analog</b> ) <sup>9)</sup>
Dosed volume	Dosed volume since last reset

<sup>9)</sup> Only DDC-AR control variant

## FlowControl

*This section applies to the DDA FCM-C control variant.*



TM086205

### DDA-C with FlowControl

The pump monitors the dosing process of liquids when the FlowControl function is activated. While the pump operates, some influences, such as air bubbles, may cause reduced flow rates or even stop the dosing process. For optimal process safety and reliability, the activated FlowControl function immediately detects and displays the following malfunctions:

- overpressure
- discharge line burst
- air bubbles in the dosing head
- cavitation at the suction side
- suction valve leakage
- discharge valve leakage.

The unique FlowControl is based on an intelligent and maintenance-free sensor integrated in the dosing head. During the dosing process, the sensor measures the actual pressure and sends the measured value to the microprocessor in the pump. An internal indicator diagram is generated combining the actual pressure value with the diaphragm position (stroke length). The dosing process is monitored so the different malfunctions can immediately be detected due to their specific deviations in the curve. Compressible air bubbles, for instance, reduce the discharge phase and the stroke volume.

The sensitivity and delay of the FlowControl function can be adjusted individually.

FlowControl requires a minimum backpressure of 2 bar. Grundfos recommends an additional spring-loaded valve (approx. 3 bar) on the discharge side for dosing low capacities, that is, below 1 l/h.

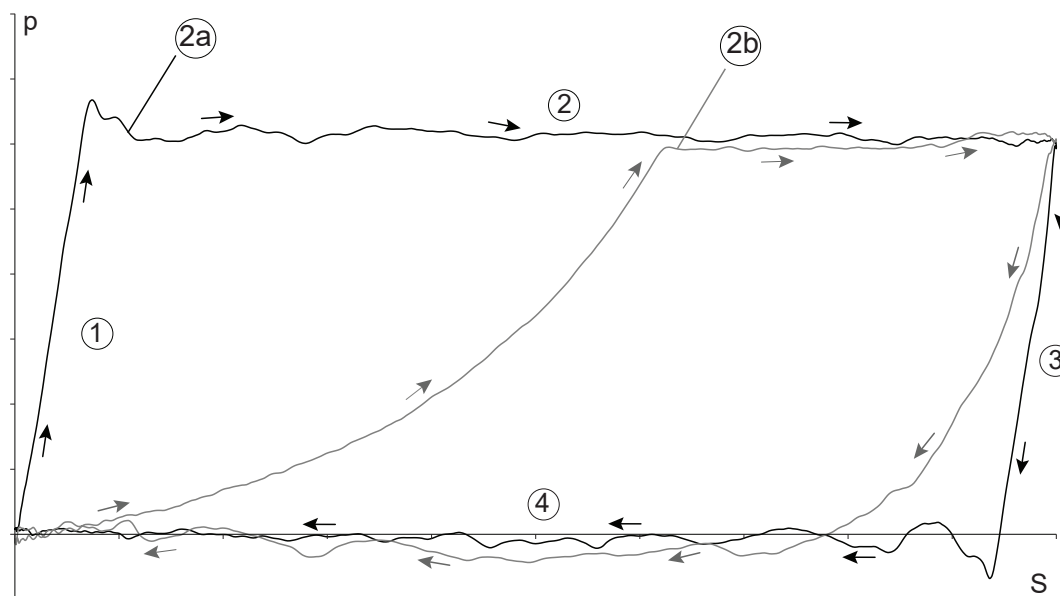

TM041610

Indicator diagram

Pos.	Description
p	Pressure
S	Stroke length
1	Compression phase
2	Discharge phase
2a	Trouble-free dosing stroke
2b	Air bubbles disturbing the dosing stroke
3	Expansion phase
4	Suction phase

### Pressure monitoring

*This section applies to the DDA FCM-C control variant.*

The integrated pressure sensor measures the actual pressure of the system which is shown in the display. A maximum pressure can be set. If the pressure in the system exceeds the set maximum, for example, if there is a closed valve, the pressure monitoring function stops the dosing process immediately. As soon as the backpressure falls below the set maximum, the dosing process continues. In case the pressure drops below the minimum limit, for example, if an discharge line bursts, the pump stops and major chemical spills are prevented.

### Pressure setting range

Pump type	Min. pressure [bar] <sup>10)</sup>	Max. pressure [bar] <sup>11)</sup>
DDA 7.5-16	2-16	3-17 (default)
DDA 12-10	2-10	3-11 (default)
DDA 17-7	2-7	3-8 (default)
DDA 30-4	2-4	3-5 (default)

<sup>10)</sup> It can be either set as a warning (pump keeps running) or as an alarm (pump stops).

<sup>11)</sup> The adjustable maximum pressure is equivalent to the maximum operating pressure plus 1 bar.

## Flow measurement

*This section applies to the DDA FCM-C control variant.*

The pump can precisely measure and display the actual dosing flow. Via the analog 0/4-20 mA output, the actual flow signal can easily be integrated in any process control system without any additional measurement equipment.

The Flow measurement function is based on an indicator diagram, see section FlowControl. Accumulating the length of each discharge stroke phase and multiplying it with the stroke frequency results in the actual flow displayed. Malfunctions, such as air bubbles or lower backpressure, result in a reduced or increased actual flow rate. When the AutoFlowAdapt function is activated, the pump compensates these influences by correcting the stroke speed. See section AutoFlowAdapt.

### Related information

[FlowControl](#)

[AutoFlowAdapt](#)

## AutoFlowAdapt

*This section applies to the DDA FCM-C control variant.*

When activating the **AutoFlowAdapt** function, even environmental changes are compensated so that the required target flow rate is achieved. The integrated **AutoFlowAdapt** makes additional monitoring and control devices redundant. The **AutoFlowAdapt** function is based on the following factors:

- FlowControl: malfunctions are detected.
- Pressure monitoring: system pressure changes are detected.
- Flow measurement: deviations in the target flow are detected.

### Examples:

- FlowControl detects air bubbles in the system. Due to a special motor drive strategy and a certain speed increase, the pump tries to keep the flow rate constant. This is especially important when dosing degassing liquids.
- In general, increasing system pressure reduces the stroke volume whereas falling system pressure increases the stroke volume. The **AutoFlowAdapt** function compensates for this by automatically and continuously adapting the motor speed. Despite fluctuating system pressure, dosing accuracy is maintained.

## New functions in the DDA-C

### Max. capacity

This function offers the possibility of reducing the maximum pump capacity for all operation modes and functions. If **Max. capacity** is set, the pump cannot operate at a higher capacity than the set maximum capacity. **Max. capacity** does not affect the function of the 100% button.

The default maximum capacity is the nominal flow of the pump.

### Stop after power failure

The **Stop after power failure** function is used to prevent the pump from performing a reference movement and start dosing when the power supply is switched on or re-established after a power failure.

A reference movement is performed every time the power supply is switched on. With the reference movement, the pump identifies the exact diaphragm position to ensure accurate dosing. Depending on the initial diaphragm position, the reference movement can dose a small amount of dosing medium into the process. To avoid this, the **Stop after power failure** function can be enabled.

The function is disabled by default.

When the function is enabled:

- The pump stops and displays an alarm when the power supply is switched on. The pump performs the reference movement after the user acknowledges the alarm.
- Functions which require the reference movement are deactivated until the reference movement is performed. These functions are the following:
  - **Auto deaeration**
  - **FlowControl**
  - Moving the diaphragm into service position
  - Volume counter.

### Communication

The pump can be integrated into various bus systems and configured via Bluetooth with the Grundfos GO app. Several communication options are available for remote configuration of the pump:

- **Bluetooth** with the Grundfos GO app
- **Bus/ Cloud control** with a CIM module
- **GENibus** with **Modbus RTU** protocol
- **Ethernet** with **Modbus TCP** protocol.

With the **Grundfos GO** app, it is possible to change the name of the pump and to manage software updates.

Manuals, functional profiles and support files, such as GSD-files, are available on Grundfos Product Center at [www.grundfos.com](http://www.grundfos.com).

### Legacy screen and Dashboard screen

Status information, such as dosing flow, selected operation mode and operating state, is displayed on the **Legacy screen** or the **Dashboard screen**.

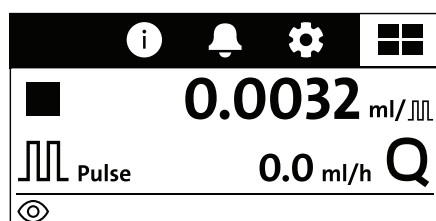

TM088256

Legacy screen with Dashboard screen icon

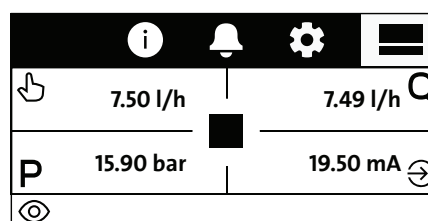

TM088257

Dashboard screen with Legacy screen icon

In the **Settings > Display > Mult. display** menu, select 1 to 3 additional values. If **Dashboard screen** is selected, the screen is split. By turning the click wheel and selecting the **Legacy screen** icon in the top bar, the display switches back to the **Legacy screen**. As long as the **Dashboard screen** is active, the **Legacy screen** icon is visible in the top bar.

### ConditionCheck

*This section applies to the DDA FCM-C.*

With the **ConditionCheck** function, an analysis of the pump and the system where the pump is installed is performed. During the analysis, a progress bar is shown.

## Wiring diagram, DDA-C

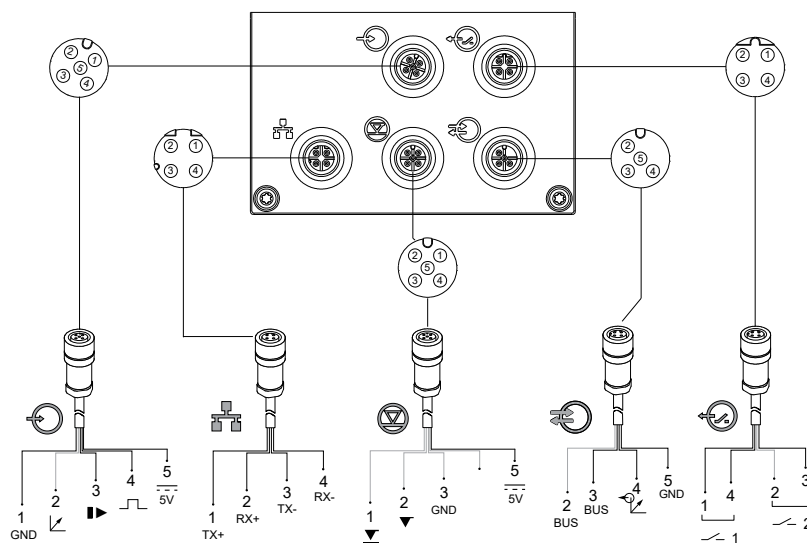

TM087929

## Input: Analog, External stop, Pulse

Function	Pins				
	1/brown	2/white	3/blue	4/black	5/yellow/green
Analog	GND / (-) mA	(+) mA			
External stop	GND		X		
Pulse	GND			X	

## Relay outputs

Function	Pins			
	1/brown	2/white	3/blue	4/black
Relay 1	X			X
Relay 2		X	X	

## Ethernet RJ45

Function	Pins			
	1/green/white	2/orange/white	3/green	4/orange
TX+ / TX-	X		X	
RX+ / RX-		X		X

## Level signals: Empty signal, Low-level signal

Function	Pins				
	1	2	3	4	5
Low-level signal	X		GND		
Empty signal		X	GND		

## GENIbus, Analog output, Modbus RTU

Function	Pins			
	2/white	3/blue	4/black	5/yellow/green
GENIbus / Modbus RTU	RS-485 A	RS-485 B		RS-485 Y
Analog output			(+) mA	GND / (-) mA

**Cable selection**

	<b>Cable 1 Analog/External stop/ Pulse</b>	<b>Cable 2 Level input</b>	<b>Cable 3 GENIbus, Analog output</b>	<b>Cable 4 Relay output</b>	<b>Cable 5 Ethernet</b>
Product No.	<ul style="list-style-type: none"> <li>• 2 m cable: 96632921</li> <li>• 5 m cable: 96632922</li> </ul>	<p>See section about suction lances and foot valves with level indication in Accessories.</p>	<ul style="list-style-type: none"> <li>• 2 m cable: 96632921</li> <li>• 5 m cable: 96632922</li> </ul>	<ul style="list-style-type: none"> <li>• 2 m cable: 96609017</li> <li>• 5 m cable: 96609019</li> </ul>	<p>It will be available in the future.</p>

**Related information**

*Rigid suction lances RSL*

## Wiring diagram, DDC

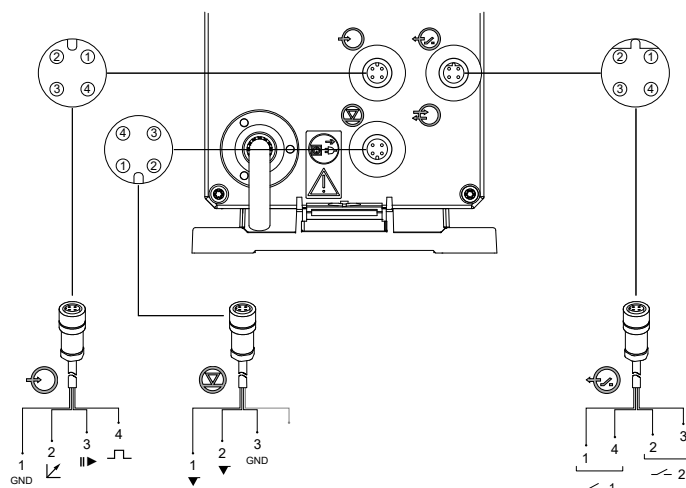

TM041187

### Input: Analog, External stop, Pulse

	Function	Pins			
		1/brown	2/white	3/blue	4/black
	Analog	GND/(-) mA	(+) mA		
	External stop	GND		X	
	Pulse	GND			X

### Level signals: Empty signal, Low-level signal

	Function	Pins			
		1	2	3	4
	Low-level signal	X		GND	
	Empty signal		X	GND	

### Relay outputs

Applies to DDC-AR control variant.

	Function	Pins			
		1/brown	2/white	3/blue	4/black
	Relay 1	X			X
	Relay 2		X	X	

### Cable selection

	Cable 1 Analog/external stop/pulse	Cable 2 Level input	Cable 4 Relay output
Product number	<ul style="list-style-type: none"> <li>2 m cable: 96609014</li> <li>5 m cable: 96609016</li> </ul>	See section about suction lances and foot valves with level indication in Accessories.	<ul style="list-style-type: none"> <li>2 m cable: 96609017</li> <li>5 m cable: 96609019</li> </ul>

### Related information

[Rigid suction lances RSL](#)

## Wiring diagram, DDE-PR, -P

This section applies to the DDE-PR/P control variant.

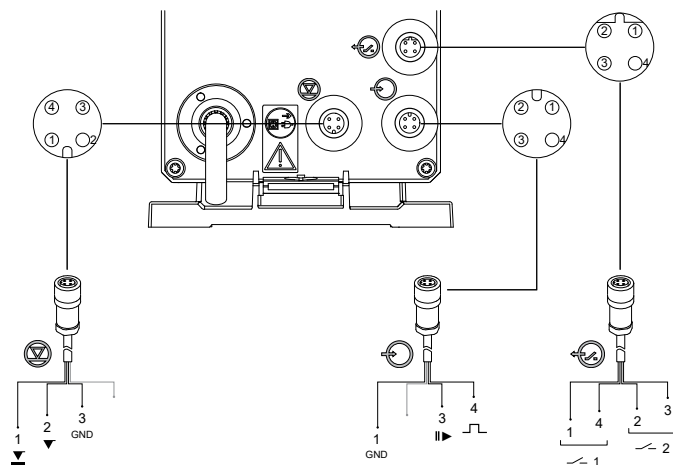

TM048172

### Input: External stop, Pulse

Function	Pins			
	1/brown	2/white	3/blue	4/black
External stop	GND		X	
Pulse	GND			X

### Level signals: Empty signal, Low-level signal

Function	Pins			
	1	2	3	4
Low-level signal	X		GND	
Empty signal		X	GND	

### Relay outputs

This section applies to the DDE-PR control variant.

Function	Pins			
	1/brown	2/white	3/blue	4/black
Relay 1 (alarm)	X			X
Relay 2 (selectable)		X	X	

### Cable selection

	Cable 1 External stop/pulse	Cable 2 Level input	Cable 4 Relay output
Product number	<ul style="list-style-type: none"> <li>2 m cable: 96609014</li> <li>5 m cable: 96609016</li> </ul>	See section about suction lances and foot valves with level indication in Accessories.	<ul style="list-style-type: none"> <li>2 m cable: 96609017</li> <li>5 m cable: 96609019</li> </ul>

### Related information

[Rigid suction lances RSL](#)

## 4. Construction

### DDA-C and DDC

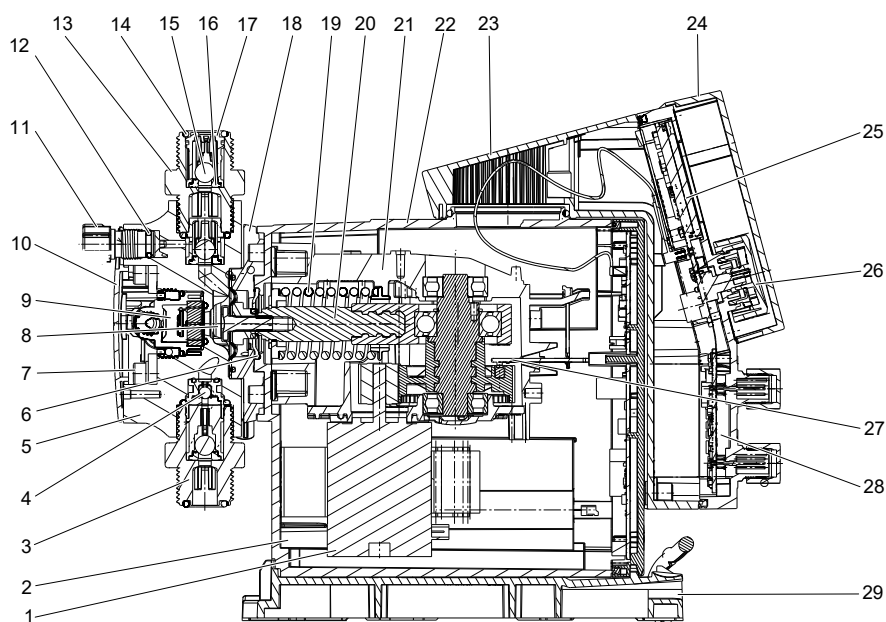

TM086941

Sectional drawing, DDA-C

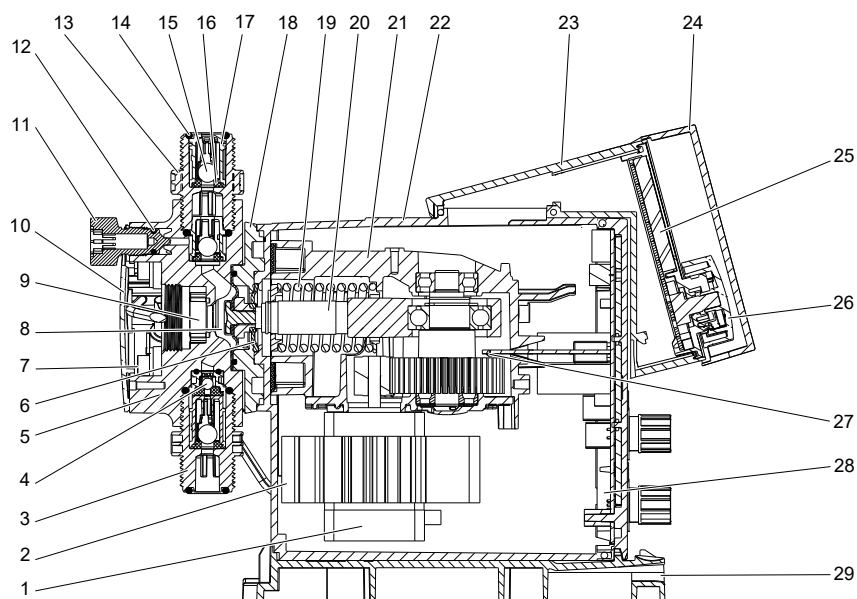

TM041533

Sectional drawing, DDC

## Construction

The DDA-C and DDC pumps are stepper motor-driven diaphragm dosing pumps consisting of the following main parts:

**Dosing head:** It has a patented design with a minimum clearance space optimised for degassing liquids. It is supplied with integrated de-aeration valve for priming and venting, complete with connection for a 4/6 mm or 0.17" × 1/4" tubing. DDA FCM-C pumps have an integrated pressure sensor in the dosing head.

**Valves:** The double-ball discharge and suction valve<sup>12)</sup> design allows for less clearance space, which is optimal for degassing liquids. Spring-loaded valves for higher viscosities are available as an option.

**Connections:** The robust and easy-to-use connection packages are optimal for various sizes of tubing or pipes.

**Diaphragm:** The full PTFE diaphragm is designed for long life and universal chemical resistance.

**Flange:** The flange is offered with separation chamber, safety diaphragm and drain hole.

**Drive unit:** It has a positive return crank with patented noiseless spur gear drive, energy recovery spring for high efficiency (only DDA-C) and stepper motor, all mounted in a robust gear housing.

**Control cube:** It contains operation electronics with display, keys, click-wheel and protective cover.

**Housing:** It contains drive unit and power electronics with robust signal sockets. The housing can be clicked on the mounting plate.

## Material specification

Pos.	Description	Material options
1	Stepper motor	-
2	Cooling element <sup>13)</sup>	Aluminium
3	Suction valve, complete <sup>14)</sup>	-
4	Valve ball, DN 4 <sup>15)</sup>	Ceramic Al <sub>2</sub> O <sub>3</sub> 99.5 %, SS 1.4401
5	Dosing head	PP, PVC, PVDF, SS 1.4435
6	Safety diaphragm	EPDM
7	Dosing head screw	SS 1.4301
8	Diaphragm	full PTFE
9	Pressure sensor	-
10	Dosing head cover	PP, SS 1.4301
11	De-aeration valve	PP, PVC, PVDF
12	De-aeration valve O-ring	EPDM/FKM
13	Discharge valve, complete <sup>14)</sup>	-
14	Discharge valve O-ring	EPDM, FKM, PTFE
15	Discharge valve ball, DN 8	Ceramic Al <sub>2</sub> O <sub>3</sub> 99.5 %, SS 1.4401
16	Discharge valve seat	EPDM, FKM, PTFE
17	Discharge valve ball cage	PP, PVC, PVDF, SS 1.4435
18	Flange	PPO/PS 20 % gf
19	Energy recovery spring <sup>13)</sup>	EN 10270-2/VD SiCr
20	Connecting rod	PA 6.6 30 % gf
21	Gear box	PPO/PS 20 % gf
22	Housing	PPO/PS 20 % gf
23	Control cube	PPO/PS 20 % gf
24	Display cover	PC
25	Operation PCB	-
26	Click wheel	PPO/PS 20 % gf
27	Hall sensor	-
28	Power PCB	-
29	Mounting plate	PPO/PS 20 % gf

<sup>13)</sup> It is only for DDA-C.

<sup>14)</sup> The pump can be supplied with spring-loaded valves (material: Tantal).

<sup>15)</sup> It is only for pumps up to 7.5 l/h with standard valves.

<sup>12)</sup> It is only for pumps up to 7.5 l/h with standard valves.

## DDE

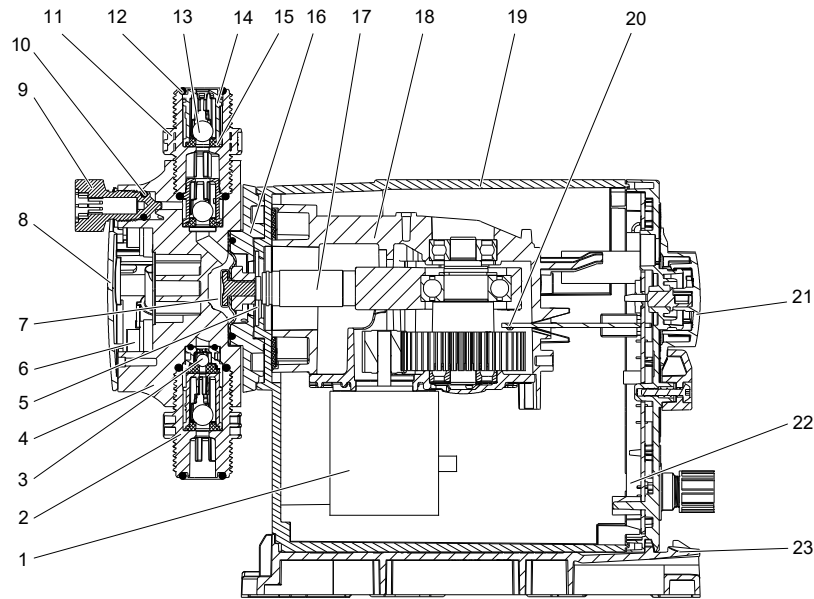

TM04:1609

Sectional drawing, DDE

## Construction

The DDE pump is a stepper motor-driven diaphragm dosing pump consisting of the following main parts:

**Dosing head:** It has a patented design with a minimum clearance space optimised for degassing liquids. It is supplied with integrated de-aeration valve for priming and venting, complete with connection for a 4/6 mm or 0.17" × 1/4" tubing.

**Valves:** The double-ball discharge and suction valve <sup>16)</sup> design allows for less clearance space optimised for degassing liquids. Spring-loaded valves for higher viscosities are available as an option.

**Connections:** The robust and easy-to-use connection packages are optimal for various sizes of tubing or pipes.

**Diaphragm:** The full PTFE diaphragm is designed for long life and universal chemical resistance.

**Flange:** The flange is offered with separation chamber, safety diaphragm and drain hole.

**Drive unit:** It has a positive return crank with patented noiseless spur gear drive and stepper motor, all mounted in a robust gear housing.

**Housing:** It contains a drive unit, control panel and electronics with robust signal sockets. The housing can be clicked on the mounting plate.

<sup>16)</sup> It is only for pumps up to 6 l/h with standard valves.

**Material specification**

Pos.	Description	Material options
1	Stepper motor	-
2	Suction valve, complete <sup>17)</sup>	-
3	Valve ball, DN 4 <sup>18)</sup>	Ceramic Al <sub>2</sub> O <sub>3</sub> 99.5 %, SS 1.4401
4	Dosing head	PP, PVC, PVDF, SS 1.4435
5	Safety diaphragm	EPDM
6	Dosing head screw	SS 1.4301
7	Diaphragm	full PTFE
8	Dosing head cover	PP, SS 1.4301
9	De-aeration valve	PP, PVC, PVDF
10	De-aeration valve O-ring	EPDM/FKM
11	Discharge valve, complete <sup>17)</sup>	-
12	Discharge valve O-ring	EPDM, FKM, PTFE
13	Discharge valve ball, DN 8	Ceramic Al <sub>2</sub> O <sub>3</sub> 99.5 %, SS 1.4401
14	Discharge valve ball cage	PP, PVC, PVDF, SS 1.4435
15	Discharge valve seat	EPDM, FKM, PTFE
16	Flange	PPO/PS 20 % gf
17	Connecting rod	PA 6.6 30 % gf
18	Gear box	PPO/PS 20 % gf
19	Housing	PPO/PS 20 % gf
20	Hall sensor	-
21	Capacity adjustment knob	PPO/PS 20 % gf
22	Power PCB	-
23	Mounting plate	PPO/PS 20 % gf

<sup>17)</sup> The pump can be supplied with spring-loaded valves (material: Tantal).

<sup>18)</sup> It is only for pumps up to 6 l/h with standard valves.

## 5. Dimensions

### Dimensions, SMART S DDA-C

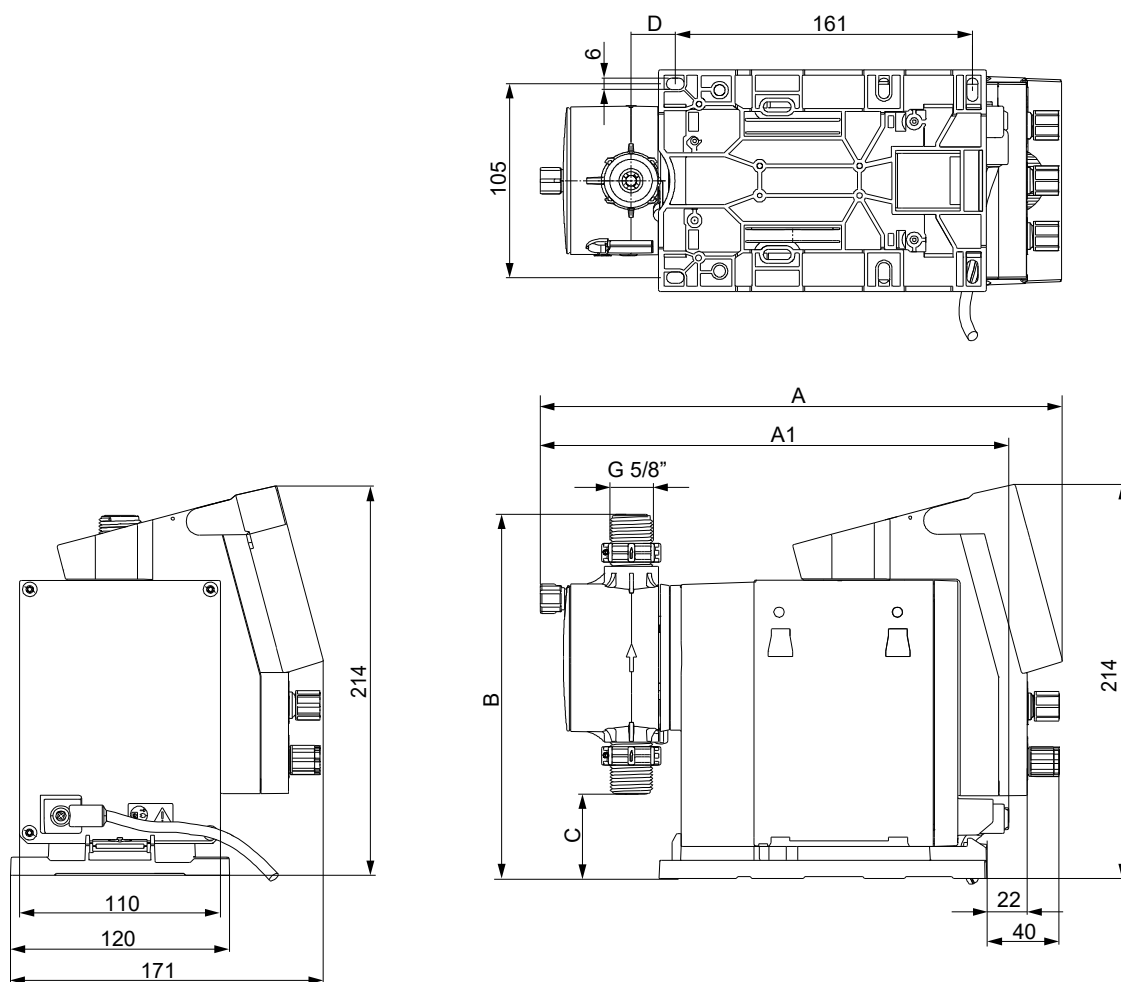

TM085794

Dimensions are provided in mm.

Pump type	A [mm]	A1 [mm]	B [mm]	C [mm]	D [mm]
DDA 7.5-16	285	255	196	46.5	24
DDA 12-10 / 17-7	285	255	200.5	39.5	24
DDA 30-4	300	270	204.5	35.5	38.5

**Dimensions, SMART S DDC**

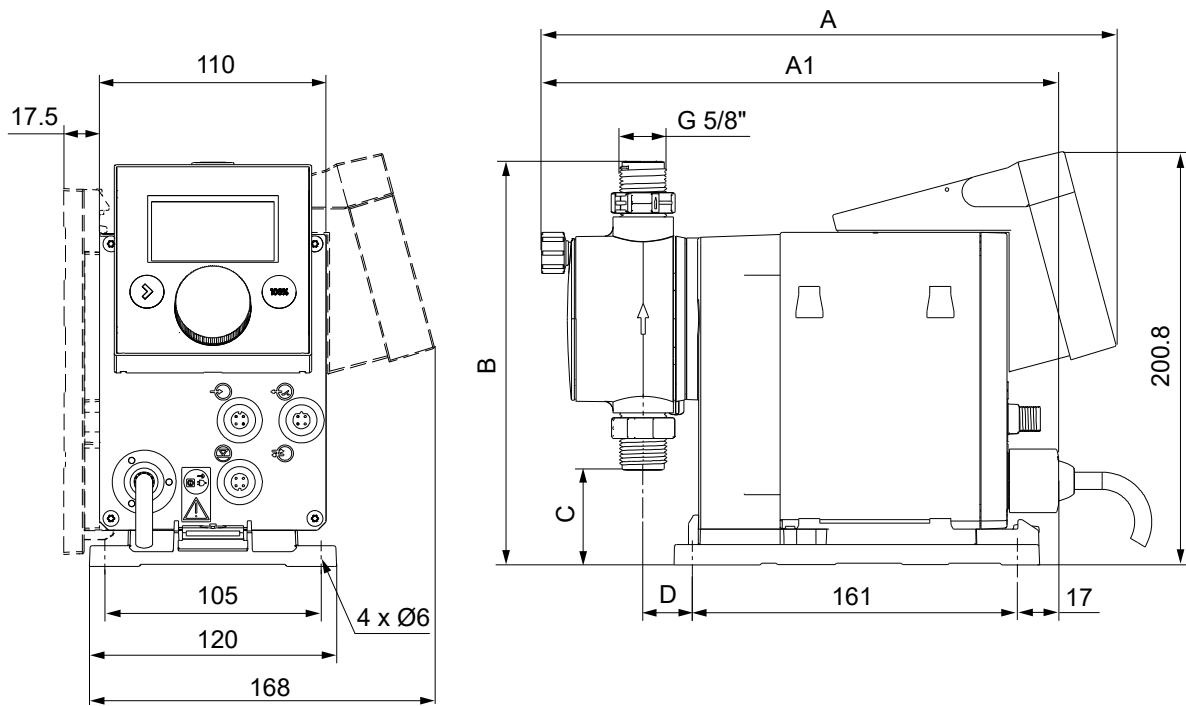

TM048169

Dimensions are provided in mm.

Pump type	A [mm]	A1 [mm]	B [mm]	C [mm]	D [mm]
DDC 6-10	280	251	196	46.5	24
DDC 9-7	280	251	196	46.5	24
DDC 15-4	280	251	200.5	39.5	24

## Dimensions, SMART S DDE

The indicated dimensions are the same for all control variants of the DDE range.  
The following drawing shows the DDE-PR control variant.

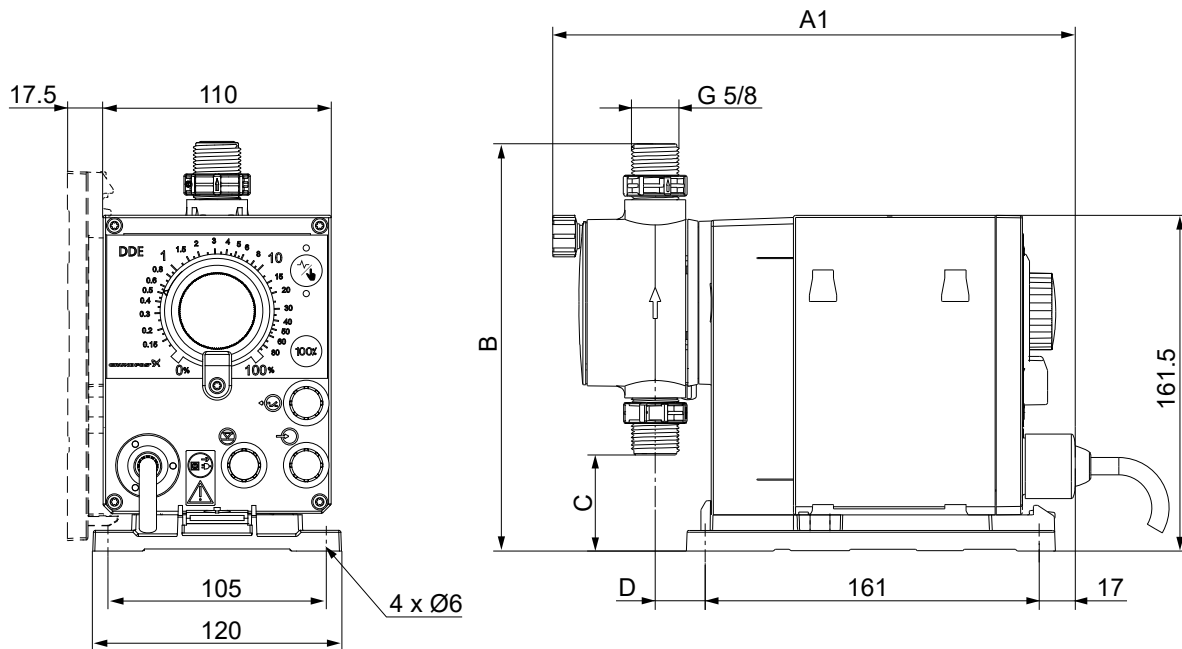

TM041147

Dimensions are provided in mm.

Pump type	A1 [mm]	B [mm]	C [mm]	D [mm]
DDE 6-10	251	196	46.5	24
DDE 15-4	251	200.5	39.5	24

## 6. Technical data

### Technical data, SMART S DDA-C

Mechanical data		7.5-16	12-10	17-7	30-4
Turn-down ratio (setting range)	[1:X]	3000	1000	1000	1000
Max. dosing capacity	[l/h]	7.5	12.0	17.0	30.0
	[gph]	2.0	3.1	4.5	8.0
Max. dosing capacity with SlowMode 50 %	[l/h]	3.75	6.00	8.50	15.00
	[gph]	1.00	1.55	2.25	4.00
Max. dosing capacity with SlowMode 25 %	[l/h]	1.88	3.00	4.25	7.50
	[gph]	0.50	0.78	1.13	2.00
Min. dosing capacity	[l/h]	0.0025	0.0120	0.0170	0.0300
	[gph]	0.0007	0.0031	0.0045	0.0080
Max. operating pressure <sup>19)</sup>	[bar]	16	10	7	4
	[psi]	230	150	100	60
Max. stroke frequency <sup>20)</sup>	[strokes/min]	190	155	205	180
Stroke volume	[ml]	0.74	1.45	1.55	3.10
Accuracy of repeatability	[%]	± 1 (of setpoint)			
Max. suction lift during operation <sup>21)</sup>	[m]	6			
Max. suction lift when priming with wet valves <sup>21)</sup>	[m]	2	3	3	2
Min. pressure differential between suction and discharge side	[bar]	1 (FCM-C: 2)			
Max. inlet pressure, suction side	[bar]	2			
Max. viscosity in SlowMode 25 % with spring-loaded valves <sup>22)</sup>	[mPas] (= cP)	2500	2500	2000	1500
Max. viscosity in SlowMode 50 % with spring-loaded valves <sup>22)</sup>	[mPas] (= cP)	1800	1300	1300	600
Max. viscosity without SlowMode with spring-loaded valves <sup>22)</sup>	[mPas]] (= cP)	600	500	500	200
Max. viscosity without spring-loaded valves <sup>22)</sup>	[mPas] (= cP)	50	300	300	150
Min. internal hose/pipe diameter suction/discharge side <sup>21)23)</sup>	[mm]	4	6	6	9
Min. internal hose/pipe diameter suction/discharge side (high viscosity) <sup>23)</sup>	[mm]	9			
Min./Max. liquid temperature	[°C]	-10/45			
Min./max. ambient temperature	[°C]	0/45			
Min./max. storage temperature	[°C]	-20/70			
Max. relative humidity (non-condensing)	[%]	96			
Max. altitude above sea level	[m]	2000			

<sup>19)</sup> PVC: up to 10 bar.

<sup>20)</sup> The maximum stroke frequency varies depending on calibration.

<sup>21)</sup> Data is based on measurements with water.

<sup>22)</sup> Maximum suction lift: 1 m, dosing capacity reduced (approx. 30 %).

<sup>23)</sup> Length of suction line: 1.5 m, length of discharge line: 10 m (at max. viscosity).

Electrical data		7.5-16	12-10	17-7	30-4
Voltage	[V]	100-240 V (- 10 %/+ 10 %), 50/60 Hz			
Length of power cable	[m]	1.5			
Max. inrush current for 2 ms (100 V)	[A]	8			
Max. inrush current for 2 ms (230 V)	[A]	25			
Max. power consumption P <sub>1</sub>	[W]	24			
Enclosure class		IP65, enclosure type 4X			
Electrical safety class		II			
Pollution degree		2			

Signal input		7.5-16	12-10	17-7	30-4
Max. load for level input		12 V, 5 mA			
Max. load for external stop input		12 V, 5 mA			
Max. load for pulse input		12 V, 5 mA			

<b>Signal input</b>		<b>7.5-16</b>	<b>12-10</b>	<b>17-7</b>	<b>30-4</b>
Min. pulse length	[ms]	0.5			
Max. pulse frequency	[Hz]	1000			
Impedance at 0/4-20 mA analog input	[Ω]	15			
Accuracy of analog input (full-scale value)	[%]	± 0.5			
Min. resolution of analog input	[mA]	0.007			
Max. resistance in level/pulse circuit	[Ω]	1000			

<b>Signal output</b>		<b>7.5-16</b>	<b>12-10</b>	<b>17-7</b>	<b>30-4</b>
Max. current on relay output (ohmic load)	[A]	0.5			
Max. frequency on relay output	[Hz]	100			
Max. voltage on relay output	[V]	30 VDC / 30 VAC			
Max. voltage on analog output	[V]	24 VDC			
Impedance at 0/4-20 mA analog output	[Ω]	500			
Accuracy of analog output (full-scale value)	[%]	± 0.5			
Min. resolution of analog output	[mA]	0.006			

<b>Weight and size</b>		<b>7.5-16</b>	<b>12-10</b>	<b>17-7</b>	<b>30-4</b>
Weight (PVC, PP, PVDF dosing head)	[kg]	2.5	2.5	2.5	2.7
Weight (stainless-steel dosing head)	[kg]	3.3	3.3	3.3	4.1
Diaphragm diameter	[mm]	44	50	50	74

<b>Sound pressure</b>		<b>7.5-16</b>	<b>12-10</b>	<b>17-7</b>	<b>30-4</b>
Max. sound pressure level	[dB(A)]	60			

**Approvals:** CE, CSA-US, NSF61, ACS, RCM.

## Technical data, SMART S DDC

Mechanical data		6-10	9-7	15-4
Turn-down ratio (setting range)	[1:X]	1000	1000	1000
Max. dosing capacity	[l/h]	6.0	9.0	15.0
	[gph]	1.5	2.4	4.0
Max. dosing capacity with SlowMode 50 %	[l/h]	3.00	4.50	7.50
	[gph]	0.75	1.20	2.00
Max. dosing capacity with SlowMode 25 %	[l/h]	1.50	2.25	3.75
	[gph]	0.38	0.60	1.00
Min. dosing capacity	[l/h]	0.0060	0.0090	0.0150
	[gph]	0.0015	0.0024	0.0040
Max. operating pressure	[bar]	10	7	4
	[psi]	150	100	60
Max. stroke frequency <sup>24)</sup>	[strokes/min]	140	200	180
Stroke volume	[ml]	0.81	0.84	1.58
Accuracy of repeatability	[%]	± 1 (of setpoint)		
Max. suction lift during operation <sup>25)</sup>	[m]	6		
Max. suction lift when priming with wet valves <sup>25)</sup>	[m]	2	2	3
Min. pressure differential between suction and discharge side	[bar]	1		
Max. inlet pressure, suction side	[bar]	2		
Max. viscosity in SlowMode 25 % with spring-loaded valves <sup>26)</sup>	[mPas] (= cP)	2500	2000	2000
Max. viscosity in SlowMode 50 % with spring-loaded valves <sup>26)</sup>	[mPas] (= cP)	1800	1300	1300
Max. viscosity without SlowMode with spring-loaded valves <sup>26)</sup>	[mPas] (= cP)	600	500	500
Max. viscosity without spring-loaded valves <sup>26)</sup>	[mPas] (= cP)	50	50	300
Min. internal hose/pipe diameter suction/discharge side <sup>25)+ 27)</sup>	[mm]	4	6	6
Min. internal hose/pipe diameter suction/discharge side (high viscosity) <sup>27)</sup>	[mm]	9		
Min./Max. liquid temperature	[°C]	-10/45		
Min./max. ambient temperature	[°C]	0/45		
Min./max. storage temperature	[°C]	-20/70		
Max. relative humidity (non-condensing)	[%]	96		
Max. altitude above sea level	[m]	2000		

<sup>24)</sup> The maximum stroke frequency varies depending on calibration.

<sup>25)</sup> Data is based on measurements with water.

<sup>26)</sup> The maximum suction lift is 1 m, dosing capacity reduced (approx. 30 %).

<sup>27)</sup> The length of the suction line is 1.5 m, the length of discharge line is 10 m (at max. viscosity).

Electrical data		6-10	9-7	15-4
Voltage	[V]	100-240 V, -10 % / +10 %, 50/60 Hz		
Length of power cable	[m]	1.5		
Max. inrush current for 2 ms (100 V)	[A]	8		
Max. inrush current for 2 ms (230 V)	[A]	25		
Max. power consumption P <sub>1</sub>	[W]	22		
Enclosure class		IP65, Type 4x		
Electrical safety class		II		
Pollution degree		2		

Signal input		6-10	9-7	15-4
Max. load for level input		12 V, 5 mA		
Max. load for pulse input		12 V, 5 mA		
Max. load for external stop input		12 V, 5 mA		
Min. pulse length	[ms]	5		
Max. pulse frequency	[Hz]	100		
Impedance at 0/4-20 mA analog input	[Ω]	15		

<b>Signal input</b>		<b>6-10</b>	<b>9-7</b>	<b>15-4</b>
Accuracy of analog input (full-scale value)	[%]		± 1.5	
Min. resolution of analog input	[mA]		0.05	
Max. resistance in level/pulse circuit	[Ω]		1000	

<b>Signal output</b>		<b>6-10</b>	<b>9-7</b>	<b>15-4</b>
Max. current on relay output (ohmic load)	[A]		0.5	
Max. frequency on relay output	[Hz]		5	
Max. voltage on relay output	[V]		30 VDC / 30 VAC	

<b>Weight and size</b>		<b>6-10</b>	<b>9-7</b>	<b>15-4</b>
Weight (PVC, PP, PVDF dosing head)	[kg]		2.4	
Weight (stainless-steel dosing head)	[kg]		3.2	
Diaphragm diameter	[mm]	44		50

<b>Sound pressure</b>		<b>6-10</b>	<b>9-7</b>	<b>15-4</b>
Max. sound pressure level	[dB(A)]		60	

**Approvals:** CE, CB, CSA-US, NSF61, EAC, ACS, RCM.

## Technical data, SMART S DDE

Mechanical data		6-10	15-4
Turn-down ratio (setting range)	[1:X]	1000	1000
Max. dosing capacity	[l/h]	6.0	15.0
	[gph]	1.5	4.0
Min. dosing capacity	[l/h]	0.006	0.015
	[gph]	0.0015	0.0040
Max. operating pressure	[bar]	10	4
	[psi]	150	60
Max. stroke frequency	[strokes/min]	140	180
Stroke volume	[ml]	0.81	1.58
Accuracy of repeatability	[%]	± 5 (of setpoint)	
Max. suction lift during operation <sup>28)</sup>	[m]	6	
Max. suction lift when priming with wet valves <sup>28)</sup>	[m]	2	3
Min. pressure differential between suction and discharge side	[bar]	1	
Max. inlet pressure, suction side	[bar]	2	
Max. viscosity with spring-loaded valves <sup>29)</sup>	[mPas] (= cP)	600	500
Max. viscosity without spring-loaded valves <sup>29)</sup>	[mPas] (= cP)	50	
Min. internal hose/pipe diameter suction/discharge side <sup>28)+ 30)</sup>	[mm]	4	6
Min. internal hose/pipe diameter suction/discharge side (high viscosity) <sup>30)</sup>	[mm]	9	
Min./max. liquid temperature	[°C]	-10/45	
Min./max. ambient temperature	[°C]	0/45	
Min./max. storage temperature	[°C]	-20/70	
Max. relative humidity (non-condensing)	[%]	96	
Max. altitude above sea level	[m]	2000	

<sup>28)</sup>Data is based on measurements with water.

<sup>29)</sup>Maximum suction lift: 1 m, dosing capacity reduced (approx. 30 %).

<sup>30)</sup>Length of suction line: 1.5 m, length of discharge line: 10 m (at max. viscosity).

Electrical data		6-10	15-4
Voltage	[V]	100-240 V, -10 % / +10 %, 50/60 Hz	
Length of power cable	[m]	1.5	
Max. inrush current for 2 ms (100 V)	[A]	8	
Max. inrush current for 2 ms (230 V)	[A]	25	
Max. power consumption P <sub>1</sub>	[W]	19	
Enclosure class		IP65, Type 4x	
Electrical safety class		II	
Pollution degree		2	

Signal input		6-10	15-4
Max. load for level input		12 V, 5 mA	
Max. load for pulse input		12 V, 5 mA	
Max. load for external stop input		12 V, 5 mA	
Min. pulse length	[ms]	5	
Max. pulse frequency	[Hz]	100	
Max. resistance in level/pulse circuit	[Ω]	1000	

Signal output		6-10	15-4
Max. current on relay output (ohmic load)	[A]	0.5	
Max. frequency on relay output	[Hz]	5	
Max. voltage on relay output	[V]	30 VDC/30 VAC	

Weight and size		6-10	15-4
Weight (PVC, PP, PVDF dosing head)	[kg]	2.4	

<b>Weight and size</b>		<b>6-10</b>	<b>15-4</b>
Weight (stainless-steel dosing head)	[kg]	3.2	
Diaphragm diameter	[mm]	44	50
<b>Sound pressure</b>		<b>6-10</b>	<b>15-4</b>
Max. sound pressure level	[dB(A)]	60	

**Approvals:** CE, CB, CSA-US, NSF61, EAC, ACS, RCM.

### Technical data for CIP (Clean-In-Place) applications

Short-term temperature limits for maximum 40 minutes at maximum 2 bar operating pressure:

Max. liquid temperature for dosing head material PVDF	[°C]	85
Max. liquid temperature for dosing head material stainless steel	[°C]	120

## 7. Pump selection

### DDA-C, standard range

Power supply: 1 x 100-240 V, 50/60 Hz (switch mode)

Mains plug: EU

Valves: Standard

Connection set: U2U2 / I001 / AA, see section Type key

Max. flow [l/h]	Max. pressure [bar]	Materials			Installation set <sup>31)</sup>	Type designation <sup>32)</sup>	Product number			
		Dosing head	Gaskets	Valve ball			AR-C	FCM-C		
7.5	16	PP	EPDM	Ceramic	No	DDA 7.5-16 <b>AR-C-PP/E/C-F-31U2U2FG</b>	93016935	93016979		
					Yes	DDA 7.5-16 <b>AR-C-PP/E/C-F-31I001FG</b>	93016936	93016980		
			FKM	Ceramic	No	DDA 7.5-16 <b>AR-C-PP/N/C-F-31U2U2FG</b>	93016937	93016981		
					Yes	DDA 7.5-16 <b>AR-C-PP/N/C-F-31I001FG</b>	93016938	93016982		
		PVC <sup>33)</sup>	EPDM	Ceramic	No	DDA 7.5-16 <b>AR-C-PVC/E/C-F-31U2U2FG</b>	93016939	93016983		
					Yes	DDA 7.5-16 <b>AR-C-PVC/E/C-F-31I001FG</b>	93016940	93016984		
			FKM	Ceramic	No	DDA 7.5-16 <b>AR-C-PVC/N/C-F-31U2U2FG</b>	93016941	93016985		
					Yes	DDA 7.5-16 <b>AR-C-PVC/N/C-F-31I001FG</b>	93016942	93016986		
			PVDF	PTFE	Ceramic	No	DDA 7.5-16 <b>AR-C-PV/T/C-F-31U2U2FG</b>	93016943	93016987	
						Yes	DDA 7.5-16 <b>AR-C-PV/T/C-F-31I001FG</b>	93016944	93016988	
		SS 1.4435	PTFE	SS 1.4401	No	DDA 7.5-16 <b>AR-C-SS/T/SS-F-31AAFG</b>	93016945	93016989		
		12	10	PP	EPDM	Ceramic	No	DDA 12-10 <b>AR-C-PP/E/C-F-31U2U2FG</b>	93016946	93016990
							Yes	DDA 12-10 <b>AR-C-PP/E/C-F-31I002FG</b>	93016947	93016991
					FKM	Ceramic	No	DDA 12-10 <b>AR-C-PP/N/C-F-31U2U2FG</b>	93016948	93016992
Yes	DDA 12-10 <b>AR-C-PP/N/C-F-31I002FG</b>						93016949	93016993		
PVC	EPDM			Ceramic	No	DDA 12-10 <b>AR-C-PVC/E/C-F-31U2U2FG</b>	93016950	93016994		
					Yes	DDA 12-10 <b>AR-C-PVC/E/C-F-31I002FG</b>	93016951	93016995		
	FKM			Ceramic	No	DDA 12-10 <b>AR-C-PVC/N/C-F-31U2U2FG</b>	93016952	93016996		
					Yes	DDA 12-10 <b>AR-C-PVC/N/C-F-31I002FG</b>	93016953	93016997		
	PVDF			PTFE	Ceramic	No	DDA 12-10 <b>AR-C-PV/T/C-F-31U2U2FG</b>	93016954	93016998	
						Yes	DDA 12-10 <b>AR-C-PV/T/C-F-31I002FG</b>	93016955	93016999	
SS 1.4435	PTFE			SS 1.4401	No	DDA 12-10 <b>AR-C-SS/T/SS-F-31AAFG</b>	93016956	93017000		
17	7			PP	EPDM	Ceramic	No	DDA 17-7 <b>AR-C-PP/E/C-F-31U2U2FG</b>	93016957	93017001
							Yes	DDA 17-7 <b>AR-C-PP/E/C-F-31I002FG</b>	93016958	93017002
					FKM	Ceramic	No	DDA 17-7 <b>AR-C-PP/N/C-F-31U2U2FG</b>	93016959	93017003
		Yes	DDA 17-7 <b>AR-C-PP/N/C-F-31I002FG</b>				93016960	93017004		
		PVC	EPDM	Ceramic	No	DDA 17-7 <b>AR-C-PVC/E/C-F-31U2U2FG</b>	93016961	93017005		
					Yes	DDA 17-7 <b>AR-C-PVC/E/C-F-31I002FG</b>	93016962	93017006		
			FKM	Ceramic	No	DDA 17-7 <b>AR-C-PVC/N/C-F-31U2U2FG</b>	93016963	93017007		
					Yes	DDA 17-7 <b>AR-C-PVC/N/C-F-31I002FG</b>	93016964	93017008		
			PVDF	PTFE	Ceramic	No	DDA 17-7 <b>AR-C-PV/T/C-F-31U2U2FG</b>	93016965	93017009	
						Yes	DDA 17-7 <b>AR-C-PV/T/C-F-31I002FG</b>	93016966	93017010	
		SS 1.4435	PTFE	SS 1.4401	No	DDA 17-7 <b>AR-C-SS/T/SS-F-31AAFG</b>	93016967	93017011		
		30	4	PP	EPDM	Ceramic	No	DDA 30-4 <b>AR-C-PP/E/C-F-31U2U2FG</b>	93016968	93017012
							Yes	DDA 30-4 <b>AR-C-PP/E/C-F-31I002FG</b>	93016969	93017013
					FKM	Ceramic	No	DDA 30-4 <b>AR-C-PP/N/C-F-31U2U2FG</b>	93016970	93017014
Yes	DDA 30-4 <b>AR-C-PP/N/C-F-31I002FG</b>						93016971	93017015		
PVC	EPDM			Ceramic	No	DDA 30-4 <b>AR-C-PVC/E/C-F-31U2U2FG</b>	93016972	93017016		
					Yes	DDA 30-4 <b>AR-C-PVC/E/C-F-31I002FG</b>	93016973	93017017		
	FKM			Ceramic	No	DDA 30-4 <b>AR-C-PVC/N/C-F-31U2U2FG</b>	93016974	93017018		
					Yes	DDA 30-4 <b>AR-C-PVC/N/C-F-31I002FG</b>	93016975	93017019		

Max. flow [l/h]	Max. pressure [bar]	Materials			Installation set <sup>31)</sup>	Type designation <sup>32)</sup>	Product number	
		Dosing head	Gaskets	Valve ball			AR-C	FCM-C
		PVDF	PTFE	Ceramic	No	DDA 30-4 <b>AR-C</b> -PV/T/C-F-31U2U2FG	93016976	93017020
					Yes	DDA 30-4 <b>AR-C</b> -PV/T/C-F-31I002FG	93016977	93017021
		SS 1.4435	PTFE	SS 1.4401	No	DDA 30-4 <b>AR-C</b> -SS/T/SS-F-31AAFG	93016978	93017022

<sup>31)</sup> The installation set includes: 2 pump connections, a foot valve, an injection unit, 6 m of PE discharge hose, 2 m PVC suction hose, 2 m of PVC de-aeration hose (4/6 mm).

<sup>32)</sup> It is also available in **FCM-C** control version.

<sup>33)</sup> PVC dosing heads only up to 10 bar

## Related information

[Type key](#)

## DDC, standard range

Power supply: 1 × 100-240 V, 50/60 Hz (switch mode)

Mains plug: EU

Valves: Standard

Connection set: U2U2 / I001 / AA, see section Type key

Max. flow [l/h]	Max. pressure [bar]	Materials			Installation set <sup>34)</sup>	Type designation <sup>35)</sup>	Product number	
		Dosing head	Gaskets	Valve ball			A	AR
6	10	PP	EPDM	Ceramic	No	DDC 6-10 <b>A</b> -PP/E/C-F-31U2U2FG	97721324	97721358
					Yes	DDC 6-10 <b>A</b> -PP/E/C-F-31I001FG	97721325	97721359
			FKM	Ceramic	No	DDC 6-10 <b>A</b> -PP/N/C-F-31U2U2FG	97721328	97721362
					Yes	DDC 6-10 <b>A</b> -PP/N/C-F-31I001FG	97721329	97721363
		PVC	EPDM	Ceramic	No	DDC 6-10 <b>A</b> -PVC/E/C-F-31U2U2FG	97721332	97721366
					Yes	DDC 6-10 <b>A</b> -PVC/E/C-F-31I001FG	97721333	97721367
			FKM	Ceramic	No	DDC 6-10 <b>A</b> -PVC/N/C-F-31U2U2FG	97721336	97721370
					Yes	DDC 6-10 <b>A</b> -PVC/N/C-F-31I001FG	97721337	97721371
		PVDF	PTFE	Ceramic	No	DDC 6-10 <b>A</b> -PV/T/C-F-31U2U2FG	97721352	97721387
					Yes	DDC 6-10 <b>A</b> -PV/T/C-F-31I001FG	97721353	97721388
		SS	PTFE	SS 1.4401	No	DDC 6-10 <b>A</b> -SS/T/SS-F-31AAFG	97721356	97721391
		9	7	PP	EPDM	Ceramic	No	DDC 9-7 <b>A</b> -PP/E/C-F-31U2U2FG
Yes	DDC 9-7 <b>A</b> -PP/E/C-F-31I002FG						97721394	97721428
FKM	Ceramic				No	DDC 9-7 <b>A</b> -PP/N/C-F-31U2U2FG	97721397	97721431
					Yes	DDC 9-7 <b>A</b> -PP/N/C-F-31I002FG	97721398	97721432
PVC	EPDM			Ceramic	No	DDC 9-7 <b>A</b> -PVC/E/C-F-31U2U2FG	97721401	97721435
					Yes	DDC 9-7 <b>A</b> -PVC/E/C-F-31I002FG	97721402	97721436
	FKM			Ceramic	No	DDC 9-7 <b>A</b> -PVC/N/C-F-31U2U2FG	97721405	97721439
					Yes	DDC 9-7 <b>A</b> -PVC/N/C-F-31I002FG	97721406	97721440
PVDF	PTFE			Ceramic	No	DDC 9-7 <b>A</b> -PV/T/C-F-31U2U2FG	97721421	97721455
					Yes	DDC 9-7 <b>A</b> -PV/T/C-F-31I002FG	97721422	97721456
SS	PTFE			SS 1.4401	No	DDC 9-7 <b>A</b> -SS/T/SS-F-31AAFG	97721425	97721459
15	4			PP	EPDM	Ceramic	No	DDC 15-4 <b>A</b> -PP/E/C-F-31U2U2FG
		Yes	DDC 15-4 <b>A</b> -PP/E/C-F-31I002FG				97721462	97721496
		FKM	Ceramic		No	DDC 15-4 <b>A</b> -PP/N/C-F-31U2U2FG	97721465	97721499
					Yes	DDC 15-4 <b>A</b> -PP/N/C-F-31I002FG	97721466	97721500
		PVC	EPDM	Ceramic	No	DDC 15-4 <b>A</b> -PVC/E/C-F-31U2U2FG	97721469	97721503
					Yes	DDC 15-4 <b>A</b> -PVC/E/C-F-31I002FG	97721470	97721504
			FKM	Ceramic	No	DDC 15-4 <b>A</b> -PVC/N/C-F-31U2U2FG	97721473	97721507
					Yes	DDC 15-4 <b>A</b> -PVC/N/C-F-31I002FG	97721474	97721508
		PVDF	PTFE	Ceramic	No	DDC 15-4 <b>A</b> -PV/T/C-F-31U2U2FG	97721489	97721523
					Yes	DDC 15-4 <b>A</b> -PV/T/C-F-31I002FG	97721490	97721524
		SS	PTFE	SS 1.4401	No	DDC 15-4 <b>A</b> -SS/T/SS-F-31AAFG	97721493	97721527

<sup>34)</sup> The installation set includes: 2 pump connections, a foot valve, an injection unit, 6 m of PE discharge hose, 2 m PVC suction hose, 2 m of PVC de-aeration hose (4/6 mm).

<sup>35)</sup> It is also available in **AR**-control version.

**Related information**

*Type key*

**DDE, standard range**

Power supply: 1 × 100-240 V, 50/60 Hz (switch mode)

Mains plug: EU

Valves: Standard

Connection set: U2U2 / I001 / AA, see section Type key

Max. flow [l/h]	Max. pressure [bar]	Dosing head	Materials		Installation set <sup>36)</sup>	Type designation <sup>37)</sup>	Product number			
			Gaskets	Valve ball			B	P	PR	
6	10	PP	EPDM	Ceramic	No	DDE 6-10 B-PP/E/C-X-31U2U2FG	97720905	97720949	98147240	
					Yes	DDE 6-10 B-PP/E/C-X-31I001FG	97720906	97720950	98147261	
			FKM	Ceramic	No	DDE 6-10 B-PP/N/C-X-31U2U2FG	97720909	97720953	98147264	
					Yes	DDE 6-10 B-PP/N/C-X-31I001FG	97720910	97720954	98147265	
			PVC	EPDM	Ceramic	No	DDE 6-10 B-PVC/E/C-X-31U2U2FG	97720923	97720957	98147268
						Yes	DDE 6-10 B-PVC/E/C-X-31I001FG	97720924	97720958	98147269
		FKM		Ceramic	No	DDE 6-10 B-PVC/N/C-X-31U2U2FG	97720927	97720961	98147272	
					Yes	DDE 6-10 B-PVC/N/C-X-31I001FG	97720928	97720962	98147273	
		PVDF	PTFE	Ceramic	No	DDE 6-10 B-PV/T/C-X-31U2U2FG	97720943	97720977	98147288	
					Yes	DDE 6-10 B-PV/T/C-X-31I001FG	97720944	97720978	98147289	
		SS	PTFE	SS 1.4401	No	DDE 6-10 B-SS/T/SS-X-31AAFG	97720947	97720981	98147292	
		15	4	PP	EPDM	Ceramic	No	DDE 15-4 B-PP/E/C-X-31U2U2FG	97720983	97721017
Yes	DDE 15-4 B-PP/E/C-X-31I002FG						97720984	97721018	98147295	
FKM	Ceramic				No	DDE 15-4 B-PP/N/C-X-31U2U2FG	97720987	97721021	98147298	
					Yes	DDE 15-4 B-PP/N/C-X-31I002FG	97720988	97721022	98147299	
PVC	EPDM				Ceramic	No	DDE 15-4 B-PVC/E/C-X-31U2U2FG	97720991	97721025	98147302
						Yes	DDE 15-4 B-PVC/E/C-X-31I002FG	97720992	97721026	98147303
	FKM			Ceramic	No	DDE 15-4 B-PVC/N/C-X-31U2U2FG	97720995	97721029	98147306	
					Yes	DDE 15-4 B-PVC/N/C-X-31I002FG	97720996	97721030	98147307	
PVDF	PTFE			Ceramic	No	DDE 15-4 B-PV/T/C-X-31U2U2FG	97721011	97721045	98147322	
					Yes	DDE 15-4 B-PV/T/C-X-31I002FG	97721012	97721046	98147323	
SS	PTFE			SS 1.4401	No	DDE 15-4 B-SS/T/SS-X-31AAFG	97721015	97721049	98147326	

<sup>36)</sup> The installation set includes: 2 pump connections, a foot valve, an injection unit, 6 m of PE discharge hose, 2 m of PVC suction hose, 2 m of PVC de-aeration hose (4/6 mm).

<sup>37)</sup> It is also available in P- and PR-control versions.

**Related information**

*Type key*

## DDA-C, DDC, DDE, non-standard range

Note that not all material combinations are possible.

Key to the three following tables:

Maximum flow - pressure	[l/h] - [bar]	
Control variant	B: Basic (DDE)	
	P: B with pulse mode (DDE)	
	PR: P with relay output (DDE)	
	A: Standard (DDC)	
	AR: A with alarm relay and analog input (DDC)	
	AR-C Standard with embedded connectivity (DDA-C)	
	FCM-C: AR-C with integrated FlowControl measurement (DDA-C)	
Materials	<b>Dosing head</b>	
	PP: PP	
	PVC: PVC (PVC dosing heads only up to 10 bar)	
	PV: PVDF	
	SS: Stainless steel 1.4401	
	<b>Gaskets</b>	
	E: EPDM	
	V: FKM	
	T: PTFE	
	<b>Valve ball</b>	
	C: Ceramic	
	SS: Stainless steel 1.4401	
	F: Front-mounted (change to left and right possible)	
X: No control cube (DDE)		
Supply voltage	3: 1 × 100-240 V, 50/60 Hz	
Valve type	1: Standard	
	2: Spring-loaded (HV version)	
Connection/Installation set	<b>Suction / discharge connection</b>	
	U2U2: Union nut G 5/8" with parts for hose connection 4/6 mm, 6/9 mm, 6/12 mm, 9/12 mm	
	U7U7: Union nut G 5/8" with parts for hose connection 0.17" × 1/4"; 1/4" × 3/8"; 3/8" × 1/2"	
	AA: Union nut G 5/8" with threaded connection Rp 1/4", internal thread	
	VV: Union nut G 5/8" with threaded connection 1/4" NPT, internal thread	
	XX: No connections included	
	<b>Installation set<sup>38)</sup></b>	
	I001: 4/6 mm (up to 7.5 l/h, 13 bar)	
	I002: 9/12 mm (up to 60 l/h, 9 bar)	
	I003: 0.17" × 1/4" (up to 7.5 l/h, 13 bar)	
	I004: 3/8" × 1/2" (up to 60 l/h, 10 bar)	
	Mains plug	F: EU
		B: USA, Canada
		G: UK
I: Australia, New Zealand		
E: Switzerland		
J: Japan		
L: Argentina		
Design	G: Grundfos red	
	A: Grundfos green (DDC)	
	B: Grundfos black	
	X: Neutral/black (DDC)	
Special variant	C: China approval	
	C3: Inspection Certificate 3.1 (EN 10204)	

<sup>38)</sup> The installation set includes 2 pump connections, foot valve, injection unit, 6 m PE discharge hose, 2 m PVC suction hose, 2 m PVC de-aeration hose (4/6 mm).

**DDA-C**

Max. flow - press.	Control variant	Materials			Control cube position	Supply voltage	Valve type	Connection/ Installation set	Mains plug	Design	Special variant
		Head	Gaskets	Ball							
7.5-16	AR-C FCM-C	PP	E V	C	F	3	1 2	U2U2 U7U7 XX I001 I003	F B G I E J L	G B C	C3
		PVC	E V	C							
		PV	T								
		SS	T	SS							
12-10 17-7 30-4	AR FC FCM	PP	E V	C	F	3	1 2	U2U2 U7U7 XX I002 I004	F B G I E J L	G B C	C3
		PVC	E V	C							
		PV	T								
		SS	T	SS							

**DDC**

Max. flow - press.	Control variant	Materials			Control cube position	Supply voltage	Valve type	Connection/ Installation set	Mains plug	Design	Special variant
		Head	Gaskets	Ball							
6-10	A AR	PP	E V	C	F	3	1 2	U2U2 U7U7 XX I001 I003	F B G I E J L	G A B X C	C3
		PVC	E V	C							
		PV	T								
		SS	T	SS							
9-7 15-4	A AR	PP	E V	C	F	3	1 2	U2U2 U7U7 XX I002 I004	F B G I E J L	G A B X C	C3
		PVC	E V	C							
		PV	T								
		SS	T	SS							

**DDE**

Max. flow - press.	Control variant	Materials			Control cube position	Supply voltage	Valve type	Connection/ Installation set	Mains plug	Design	Special variant
		Head	Gaskets	Ball							
6-10	B P PR	PP	E V	C	X	3	1 2	U2U2 U7U7 XX I001 I003	F B G I E J L	B C	C3
		PVC	E V	C							
		PV	T								
		SS	T	SS							
15-4	B P PR	PP	E V	C	X	3	1 2	U2U2 U7U7 XX I002 I004	F B G I E J L	B C	C3
		PVC	E V	C							
		PV	T								
		SS	T	SS							

## 8. Accessories for small dosing pumps up to 60 l/h

### Accessories overview

Grundfos offer a comprehensive range of accessories covering every need when dosing with Grundfos pumps.

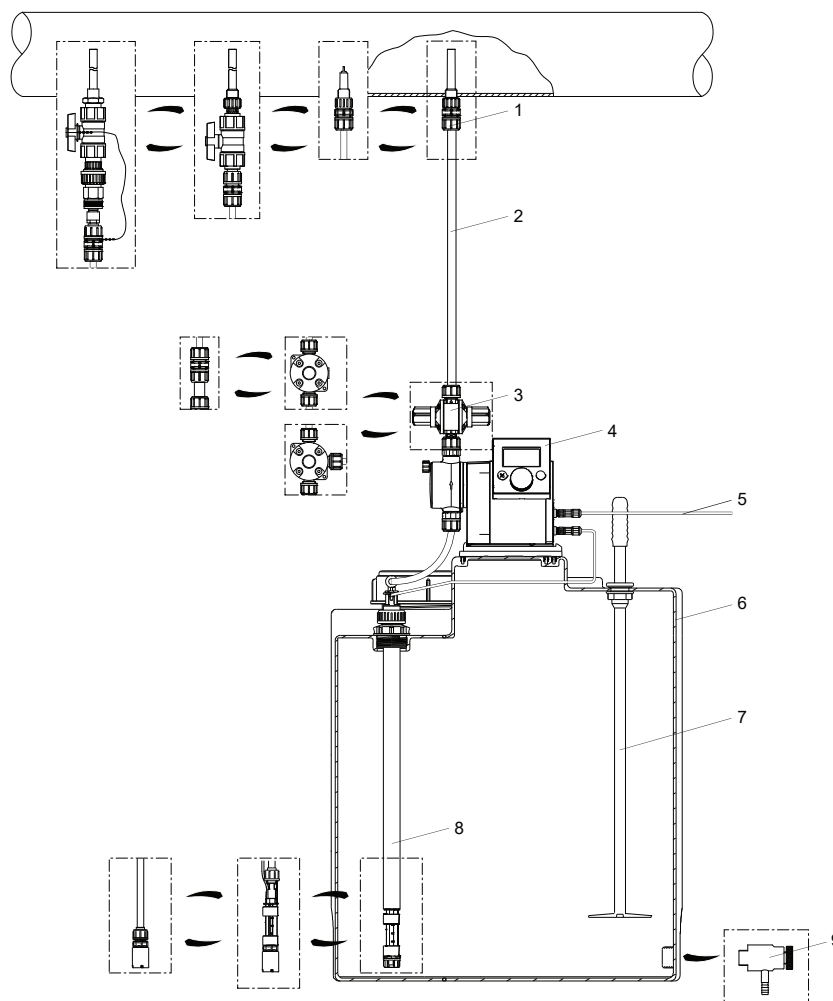

TM086937

#### Dosing pump with accessories

Pos.	Description
1	Injection units See sections Injection units
2	Hoses See section Hoses.
3	Multi-function valves, pressure-loading valves, pressure-relief valves, pressure valves See sections Multi-function valves, Pressure-loading valves, Pressure-relief valves PRV, and Pressure valves.
4	Example: SMART Digital dosing pump
5	Cables See section Cables and plugs.
6	Dosing tanks See section Adapters.
7	Handheld mixer See section Accessories for dosing tanks.
8	Foot valves and rigid suction lances See sections Foot valves FV and Rigid suction lances RSL.

Pos.	Description
9	Drain valves See section Accessories for dosing tanks.
-	Installation kits: Pump connection kits and inlay kits Adapters T-pieces See section Installation kits for dosing pumps.
-	Accessories for hydraulic connection

#### Related information

*Installation kits for dosing pumps*

*Cables and plugs*

*Hoses*

*Foot valves FV*

*Rigid suction lances RSL*

*Injection units*

*Hot-injection units with ball valve*

*Multi-function valves, pressure-relief valves, pressure-loading valves*

*Pump connection kits and inlay kits*

*Threaded adapters*

*Union nut adapters*

*Square tank, 100 litres*

*Cylindrical tanks*

*Accessories for dosing tanks*

## Installation kits for dosing pumps

An installation kit includes the following parts:

- injection unit with spring-loaded non-return valve, see section Injection units
- PE discharge hose, 6 m
- PVC suction hose, 2 m
- PVC de-aeration hose, 2 m
- PE foot valve with strainer and weight, without or with level indication, see section Foot valves FV.



*Installation kit with foot valve without level indication*



*Installation kit with foot valve with level indication*

TM085687

TM085684

## Technical data

Max. flow rate <sup>39)</sup> [l/h]	Max. pressure [bar]	Size		Material of injection unit			Product number					
		Suction / discharge hose [mm]	De-aeration hose [mm]	Body	Gasket	Ball	Foot valve without level indication	Foot valve with level indication				
7.5	13	4/6	4/6	PP	FKM	Ceramic	95730440	95730464				
					EPDM	Ceramic	95730441	95730465				
				PVC	FKM	Ceramic	95730442	95730466				
					EPDM	Ceramic	95730443	95730467				
					PTFE	Ceramic	95730444	95730468				
				PVDF	FKM	Ceramic	95730445	95730469				
					EPDM	Ceramic	95730446	95730470				
					PTFE	Ceramic	95730447	95730471				
				30	12	6/9	4/6	PP	FKM	Ceramic	95730448	95730472
									EPDM	Ceramic	95730449	95730473
								PVC	FKM	Ceramic	95730450	95730474
									EPDM	Ceramic	95730451	95730475
PTFE	Ceramic	95730452	95730476									
PVDF	FKM	Ceramic	95730453					95730477				
	EPDM	Ceramic	95730454					95730478				
	PTFE	Ceramic	95730455					95730479				
60	9	9/12	4/6					PP	FKM	Ceramic	95730456	95730480
									EPDM	Ceramic	95730457	95730481
								PVC	FKM	Ceramic	95730458	95730482
									EPDM	Ceramic	95730459	95730483
				PTFE	Ceramic	95730460	95730484					
				PVDF	FKM	Ceramic	95730461	95730485				
					EPDM	Ceramic	95730462	95730486				
					PTFE	Ceramic	95730463	95730487				

<sup>39)</sup> Viscosity similar to water

## Cables and plugs

The listed cables and plugs are suitable for connecting a pump to external control devices, such as process controllers, flow meters, start/stop contacts, or level sensors.



TM048267

Cable and plug

### Technical data

- Cable material: PVC, 0.34 mm<sup>2</sup>
- Plug size: M 12

Socket	Application	Pins	Plug type	Cable length [m]	Product number	
	Input	4 (DDC)	Straight	2	96609014	
				5	96609016	
			No cable		96698715	
			Angled	2	96693246	
		5 (DDA-C)	Straight	2	96632921	
				5	96632922	
			No cable		96609031	
			Angled	2	96699697	
	Input	Low level Empty tank	4	Straight	No cable	96698715
					No cable	
	Output	Analog	5	Straight	2	96632921
					5	96632922
	No cable		96609031			
	Input/Output	GENIbus / Modbus	5	Straight	2	96699697
3					98589048	
	Output	Relay 1 Relay 2	4	Straight	2	96609017
					5	96609019
				No cable		96696198
				Angled	2	96698716

## Hoses

Hoses are available in various materials, sizes and lengths for small dosing pumps.



TM048268

Hoses

**Related information**[Foot valves FV](#)[Injection units](#)**Technical data**

Max. flow rate <sup>40)</sup> [l/h]	Size (internal/external diameter) [mm]	Material	Max. pressure at 20 °C [bar]	Length [m]	Product number	
7.5	4/6	PE	13	3	91835676	
				10	91836504	
				50	91835680	
		PVC	0.5	3	96701733	
				10	96702133	
				50	96727418	
	ETFE	20	3	95730337		
			10	95730338		
			50	95730339		
17	5/8	PE	13	3	95730888	
				10	96727393	
				50	95730889	
		PE	12	3	96727409	
				10	96727412	
				50	96727415	
	30	6/9	PVC	0.5	3	95730334
					10	95730335
					50	95730336
ETFE		20	3	95730340		
			10	95730341		
			50	95730342		
60	6/12	PVC, textile-reinforced	23	3	96693751	
				10	96653571	
				50	91835686	
		PE	9	3	96727395	
				10	96705657	
				50	96727398	
	PVC	0.5	3	96727434		
			10	95730890		
			50	95724702		
ETFE	13	3	95730343			
		10	95730344			
		50	95730345			

<sup>40)</sup> Viscosity similar to water

## Foot valves FV

Foot valves are installed at the lower end of the suction hose. They are available either without level indication or with low-level and empty-tank indication.

Foot valves include:

- weight
- strainer (mesh size approx. 0.8 mm)
- non-return valve
- hose connection set: 4/6 mm, 6/9 mm, 6/12 mm and 9/12 mm
- pipe connection set: threaded, Rp 1/4", internal thread (stainless steel).

Foot valves with low-level and empty-tank indication additionally include:

- reed-switch unit with two floaters
- 5 meters of cable with PE jacket
- M 12 plug to connect DDA-C, DDC, or DDE dosing pump
- PE cap, Ø58 mm, for assembly in Grundfos cylindrical tanks, or for use with tank adapters.

The contact type of the low-level and empty-tank indication is factory-set to NO. The contact type can be set to NC by turning the floaters upside down.

Electrical data of the level indication:

- max. voltage: 48 V
- max. current: 0.5 A
- max. load: 10 VA.



Foot valves: without level indication (left), with level indication (right)

TM085698

Dimensions

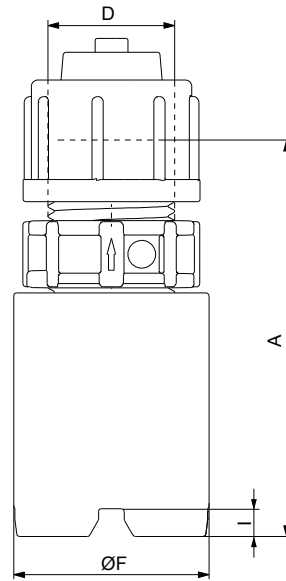

TM086081

*FV without level indication, PE/PVDF; with ceramic weight*

A [mm]	D	ØF [mm]	l [mm]
71.8	G 5/8	35	5

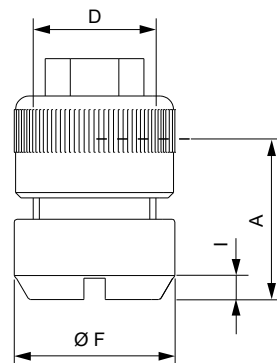

TM048494

*FV without level indication, stainless steel*

A [mm]	D	ØF [mm]	l [mm]
30	G 5/8	30	4

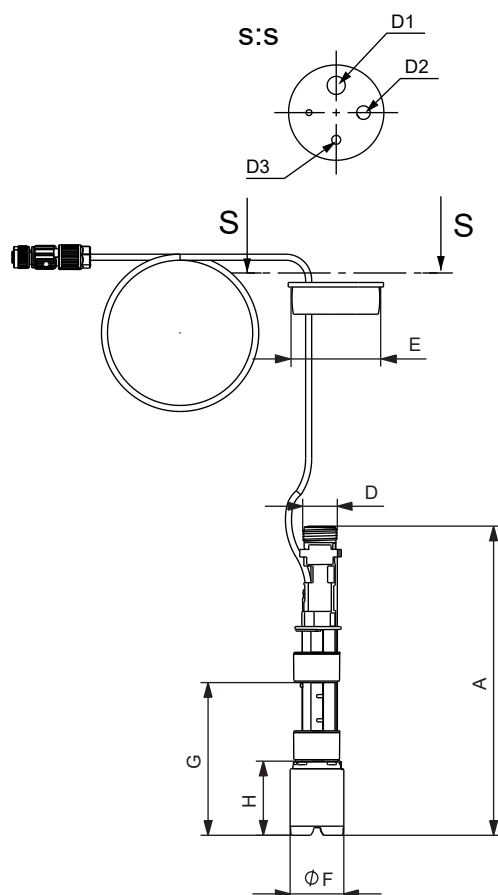

TM082553

FV with level indication

A [mm]	D	D1/D2/D3 [mm]	E [mm]	ØF [mm]	G [mm]	H [mm]
204	G 5/8	12/9/6	58	35	101	49

### Technical data

Max. flow rate [l/h]	Material			Product number	
	Body	Gasket	Ball	Without level indication	With level indication
60	PE	FKM, EPDM	Ceramic	98070951	98070966
		PTFE	Ceramic	98070952	98070967
	PVDF	FKM, EPDM	Ceramic	98070953	98070968
		PTFE	Ceramic	98070954	98070969
	SS	PTFE	SS	98070963	-

## Rigid suction lances RSL

Grundfos offers a comprehensive range of rigid suction lances for a variety of chemical containers.

Rigid suction lances are installed at the lower end of the suction hose. They are available either without level indication or with low-level and empty-tank indication. Their immersion depth is adjustable.

Rigid suction lances include:

- strainer (mesh size approx. 0.8 mm)
- non-return valve
- hose connection set: 4/6 mm, 6/9 mm, 6/12 mm and 9/12 mm
- adjustable tank connection with holes, for example, relief line.

Rigid suction lances with low-level and empty-tank indication additionally include:

- reed-switch unit with 2 floaters
- 5 meters of cable with PE jacket
- M 12 plug to connect DDA-C, DDC, or DDE dosing pump.

The contact type of the low-level and empty-tank indication is factory-set to NO. The contact type can be set to NC by turning the floaters upside down.

Electrical data of the level indication:

- max. voltage: 48 V
- max. current: 0.5 A
- max. load: 10 VA.



TMO48458

*Rigid suction lance*

## Dimensions

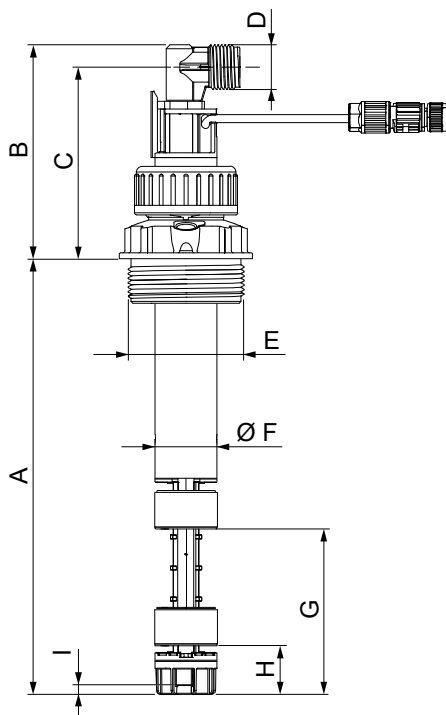

TM048445

RSL with or without level indication

A [mm]	B [mm]	C [mm]	D	E	ØF [mm]	G [mm]	H [mm]	I [mm]
400								
500								
570								
690								
820	110	99	G 5/8	G 2	32	85	25	4.5
980								
1100								
1200								

## Dosing tank selection

For dosing tank type	Tank volume	Recommended immersion depth
	[l]	[mm]
Grundfos cylindrical tank, see section Cylindrical tanks	40	400
	60	500
	100	690
	200	690
	300	980
	500	1100
Grundfos square tank, see section Square tank, 100 litres <sup>41)</sup>	100	690
	120	820
L-ring drum <sup>41)</sup>	220	980
	216	980
Steel drum <sup>41)</sup>	12, 33 (large cap)	400
	25, 30, 33	500
	60	690
IBC <sup>41)</sup>	all sizes	1200

<sup>41)</sup> For suitable adapters, see section Adapters for containers.

**Related information**

*Adapters for containers*

*Square tank, 100 litres*

*Cylindrical tanks*

**Technical data**

Max. flow rate [l/h]	Max. immersion depth <sup>42)</sup> [mm]	Material			Product number	
		Body	Gasket	Ball	RSL without level indication	RSL with level indication
60	400	PE	FKM, EPDM	Ceramic	98070978	98071074
			PTFE	Ceramic	98070979	98071075
		PVDF	FKM, EPDM	Ceramic	98070980	98071076
			PTFE	Ceramic	98070981	98071077
	500	PE	FKM, EPDM	Ceramic	98070990	98071086
			PTFE	Ceramic	98070991	98071087
		PVDF	FKM, EPDM	Ceramic	98070992	98071088
			PTFE	Ceramic	98070993	98071089
	570	PE	FKM, EPDM	Ceramic	98071002	98071098
			PTFE	Ceramic	98071003	98071099
		PVDF	FKM, EPDM	Ceramic	98071004	98071100
			PTFE	Ceramic	98071005	98071101
	690	PE	FKM, EPDM	Ceramic	98071014	98071110
			PTFE	Ceramic	98071015	98071111
		PVDF	FKM, EPDM	Ceramic	98071016	98071112
			PTFE	Ceramic	98071017	98071113
	820	PE	FKM, EPDM	Ceramic	98071026	98071122
			PTFE	Ceramic	98071027	98071123
		PVDF	FKM, EPDM	Ceramic	98071028	98071124
			PTFE	Ceramic	98071029	98071125
	980	PE	FKM, EPDM	Ceramic	98071038	98071134
			PTFE	Ceramic	98071039	98071135
		PVDF	FKM, EPDM	Ceramic	98071040	98071136
			PTFE	Ceramic	98071041	98071137
1100	PE	FKM, EPDM	Ceramic	98071050	98071146	
		PTFE	Ceramic	98071051	98071147	
	PVDF	FKM, EPDM	Ceramic	98071052	98071148	
		PTFE	Ceramic	98071053	98071149	
1200	PE	FKM, EPDM	Ceramic	98071062	98071158	
		PTFE	Ceramic	98071063	98071159	
	PVDF	FKM, EPDM	Ceramic	98071064	98071160	
		PTFE	Ceramic	98071065	98071161	

<sup>42)</sup> Minimum immersion depth for all sizes: approx. 140 mm.

## Accessories for suction lances and foot valves with level indication

### Adapters for containers

These adapters allow the installation of standard rigid suction lances (G 2" thread) and foot valves with level indication (PE cap) on different types of containers.



TM048506

Adapters for containers

### Technical data

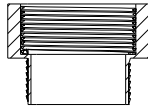
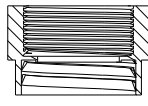
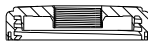
Adapter type	For container type	Remark	Product number
	Counter nut for tanks without threaded opening, for example, 100-litre square tank or 1000-litre cylindrical tank	PVC, grey	98071170
	Containers with 2" NPT threaded opening	PVC, grey	98156690
	Drums with S 70 × 6 coarse thread (MAUSER 2")	PE, blue	98071171
	Drums with S 56 × 4 coarse thread (TriSure®)	PE, orange	98071172
	Jerricans with small opening (approx. Ø36), according to EN 12713	PE, green	98071173
	Jerricans with medium-sized opening (approx. Ø45), according to EN 12713	PE, yellow	98071174
	Jerricans with large opening (approx. Ø57), according to EN 12713	PE, brown	98071175
	US containers with bung hole of 63 mm (ASTM International)	PE, white	98071176
	IBC (Intermediate Bulk Container) with opening of Ø150 mm, S 160 × 7	PE, black	98071177

### Emission protection kits

Gas emitted by liquid in a container can cause bad odour and corrosion. Emission protection kits help avoid such problems.

Rigid suction lances can be retrofitted with emission protection kits.

Two variants are available:

- Emission protection kit with snifting valve: no gas can escape from the container, but air can be drawn in.
- Emission protection kit for use with filter: gas can escape from the container and air can be drawn in. The kit can be connected to a filter by a 4/6 mm hose.

Emission protection kits include:

- gasket for the tank adapter
- snifting valve or hose nipple 4/6 mm (hose is not included)
- gasket for the cable outlet.

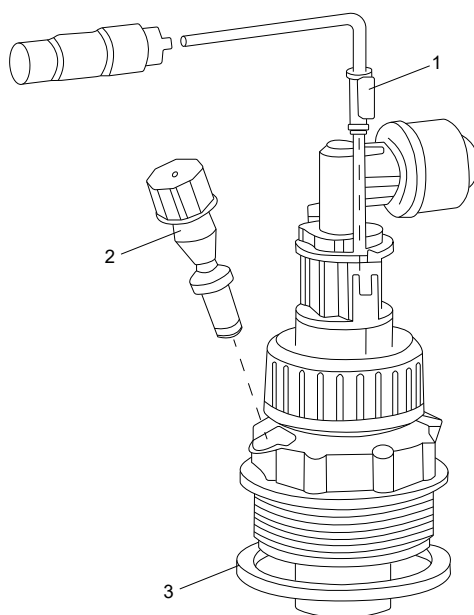

TM069068

#### Emission protection kit

Pos.	Description
1	Gasket for the cable outlet
2	Snifting valve
3	Gasket for the tank adapter

### Order data

Variant	Product number
Emission protection kit with snifting valve	98071178
Emission protection kit for use with filter	98071179

### M 12-plug-to-flat-plug adapter

The adapter allows for connecting rigid suction lances or foot valves with level indication to pumps with a level input designed for flat plugs, for example, the DMX and the DMH with AR control unit.

#### Order data

Description	Product number
M 12-plug-to-flat-plug adapter	96635010

## Injection units

Injection units connect the dosing line with the process line. They ensure a minimum counterpressure of 0.7 bar and prevent backflow of the dosing liquid.

In general, they include the following:

- injection pipe (PP, PVC and PVDF versions can be shortened)
- spring-loaded non-return valve with Tantal spring
- hose connection set: 4/6 mm, 6/9 mm, 6/12 mm and 9/12 mm
- pipe connection set: threaded, Rp 1/4", internal thread (stainless steel).

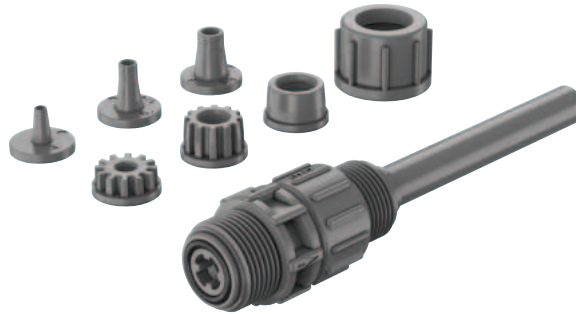

TM087076

*Standard injection unit*

## Standard injection units

### Dimensions

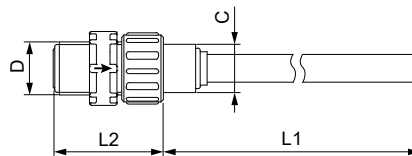

TM069845

*Standard injection unit, PP, PVC, and PVDF version*

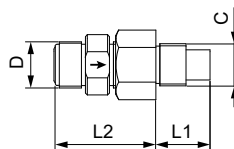

TM069846

*Standard injection unit, stainless-steel version*

Material	C	L1 in [mm]	L2 in [mm]	D
PVC	1/2" NPT (G 1/2)	4 / 12 (100 / 300)	1.8 (47)	5/8" NPT (G 5/8)
PP, PVDF	1/2" NPT (G 1/2)	4 (100)	1.8 (47)	5/8" NPT (G 5/8)
Stainless steel	1/2" NPT (G 1/2)	1 (27)	1.9 (50)	5/8" NPT (G 5/8)

**Technical data**

Max. flow rate [l/h]	Max. pressure [bar]	Material			Dimensions		Product number
		Body	Gasket	Ball	L1 [mm]	L2 [mm]	
60	16	PP	FKM	Ceramic	100	47	95730904
			EPDM	Ceramic	100	47	95730908
		PVC	FKM	Ceramic	100	47	95730912
			EPDM	Ceramic	100	47	95730916
		PVDF	PTFE	Ceramic	100	47	95730920
			FKM	Ceramic	100	47	95730924
	100	Stainless steel	PTFE	Stainless steel	27	50	95730936
			FKM	Ceramic	300	47	95730940
		PVC	EPDM	Ceramic	300	47	95730944
			PTFE	Ceramic	300	47	95730948

**Injection units with lip valve**

Injection units with lip valve are typically used for adding sodium hypochlorite solution to water with a high carbonate content. The FKM lip prevents crystallisation and blocking caused by alkali carbonate reactions at the point of injection.

**Dimensions**

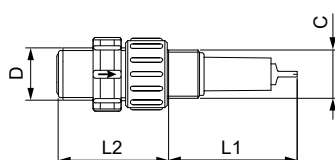

TM069847

*Injection unit with lip valve*

C	L1 in [mm]	L2 in [mm]	D
G 1/2	55	49	G 5/8

**Technical data**

Max. flow rate [l/h]	Max. pressure [bar]	Material			Dimensions		Product number
		Body	Gasket	Ball	L1 [mm]	L2 [mm]	
60	16	PVC	FKM	Ceramic	55	59	95730964

**Injection units with ball valve**

Injection units with ball valve are used for applications where the injection point must be closable. The ball valve is placed between the injection pipe and the spring-loaded non-return valve.

- The dosing line can be completely disconnected from the process.
- The non-return valve can be dismantled and cleaned without stopping the process and emptying the process line.

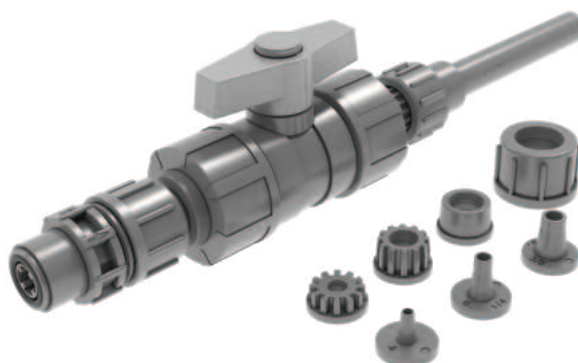

TM088267

## Dimensions

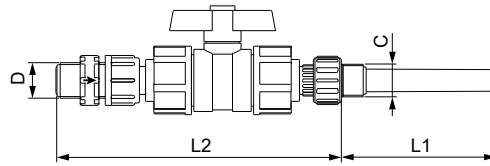

TM069848

Injection unit with ball valve

	C	L1 in [mm]	L2 in [mm]	D
PVC	G 1/2	100	183	G 5/8
Stainless steel	G 1/2	27	138	G 5/8

## Technical data

Max. flow rate [l/h]	Max. pressure [bar]	Material			Dimensions		Product number
		Body	Gasket	Ball	L1 [mm]	L2 [mm]	
60	16	PVC	FKM	Ceramic	100	183	95730952
			EPDM	Ceramic	100	183	95730956
	64	Stainless steel	PTFE	Stainless steel	27	138	95730960

## Injection units with removable injection pipe

Injection units with removable injection pipe are used where regular cleaning of the injection pipe is required. The injection pipe can be removed from the process line without stopping the process water flow. The injection point can be closed with the integrated ball valve. The immersion depth of the injection pipe can be adjusted.

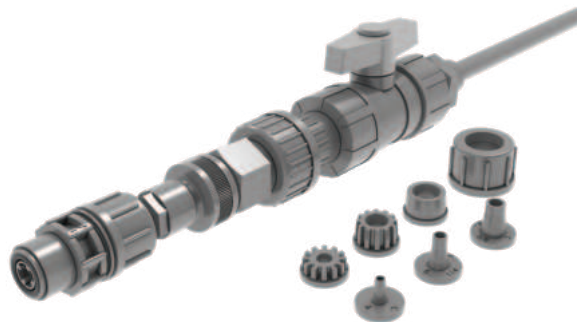

TM088288

## Dimensions

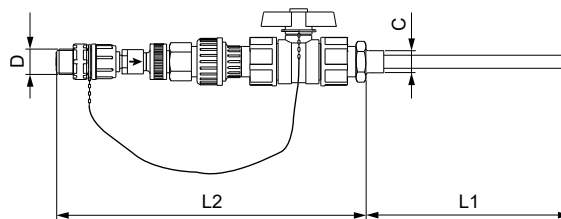

TM069849

Injection unit with removable injection pipe

C	L1 in [mm]	L2 in [mm]	D
G 1/2	185	280	G 5/8

**Technical data**

Max. flow rate [l/h]	Max. pressure [bar]	Material			Dimensions		Product number
		Body	Gasket	Ball	L1 [mm]	L2 [mm]	
60	10	PVC	FKM	Ceramic	185	280	95730968
			EPDM	Ceramic	185	280	95730972

**Hot-injection units with ball valve**

Hot-injection units with ball valve can be used for direct injection of the dosing medium into processes with a high process water temperature of up to 120 °C. Hot-injection units have a stainless-steel injection pipe and a bendable stainless-steel cooling pipe of 1 metre. The stainless-steel ball valve is installed between the injection pipe and the cooling pipe. The cooling pipe separates the hot parts from the non-return valve and the dosing line.

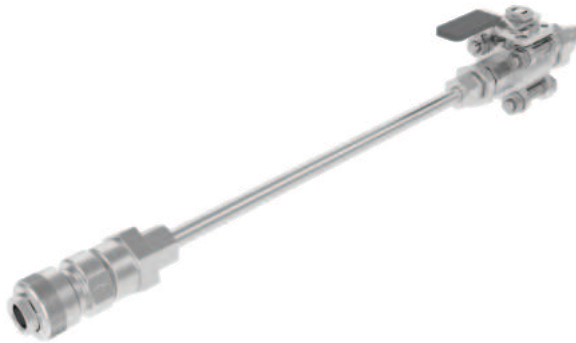

TM088269

**Dimensions**

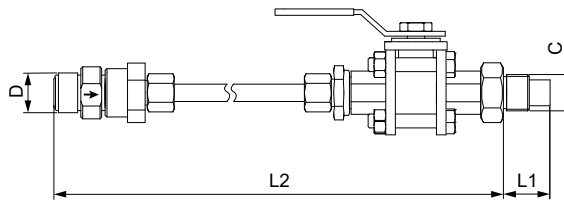

TM069850

*Hot-injection unit with ball valve*

C	L1 in [mm]	L2 in [mm]	D
G 1/2	27	1158	G 5/8

**Technical data**

Max. flow rate [l/h]	Max. pressure [bar]	Material			Dimensions		Product number
		Body	Gasket	Ball	L1 [mm]	L2 [mm]	
60	16	PVDF	PTFE	Ceramic	27	1158	95730976
	64	Stainless steel	PTFE	Stainless steel	27	1158	95730980

## Multi-function valves, pressure-relief valves, pressure-loading valves

Multi-function valves combine the functions of pressure-relief valves and pressure-loading valves. In addition, they allow de-aeration of the pump and emptying of the discharge line for maintenance.

Pressure-relief valves protect the pump and the discharge-side installations against excessive pressure. All pressurised dosing installations should include a pressure-relief valve.

Pressure-loading valves maintain a certain counterpressure for the dosing pump.

They are used in the following cases:

- If the counterpressure is too low or there is no counterpressure at all.
- There is fluctuating system pressure with discharge-side pulsation damper.
- To prevent syphoning when the inlet pressure is higher than the counterpressure.



TM086554

*Multi-function valve, pressure-relief valve, pressure-loading valve*

### Multi-function valves

A multi-function valve is mounted directly on the pump discharge side. The top connection is for the discharge line, the side connection leads the relief liquid back into the tank.

- Loading pressure, adjustable from 1 to 4 bar, is factory-set to 3 bar.
- Relief pressure, adjustable from 7 to 16 bar, is factory-set to 10 bar or 16 bar.
- Maximum operating pressure: 16 bar.
- Hose connection set: 4/6 mm, 6/9 mm, 6/12 mm, and 9/12 mm.

### Dimensions

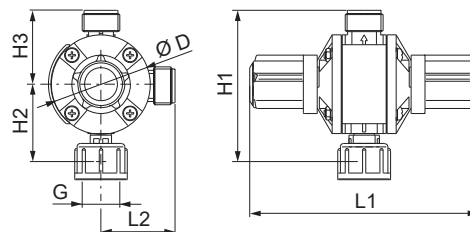

TM069769

*Multi-function valve*

L1 in (mm)	L2 in (mm)	H1 in (mm)	H2 in (mm)	H3 in (mm)	ØD in (mm)	G
139	45	92	47	45	60	G 5/8

### Technical data

Max. flow rate [l/h]	Material				Product number	
	Body	Connections	Gasket	Diaphragm	Relief pressure 10 bar	Relief pressure 16 bar
60	PP	PP	FKM	PTFE	95704585	95730821
			EPDM	PTFE	95704591	95730822
		PVC	FKM	PTFE	95730807	95730823
			EPDM	PTFE	95730808	95730824
	PVDF	PVC	PTFE	PTFE	95730809	95730825
			FKM	PTFE	95730810	95730826
		PVDF	EPDM	PTFE	95730811	95730827
			PTFE	PTFE	95730812	95730828

### Pressure-relief valves PRV

Pressure-relief valves are installed in the discharge line near the pump, using the 2 in-line connections. The side connection leads the relief liquid back into the tank.

- Relief pressure, adjustable from 5 to 10 bar, is factory-set to 10 bar.
- Relief pressure, adjustable from 7 to 16 bar, is factory-set to 16 bar.
- Maximum operating pressure: 16 bar.
- Hose connection set: 4/6 mm, 6/9 mm, 6/12 mm, and 9/12 mm.
- Pipe connection set: threaded, Rp 1/4", internal thread (stainless steel).

### Dimensions

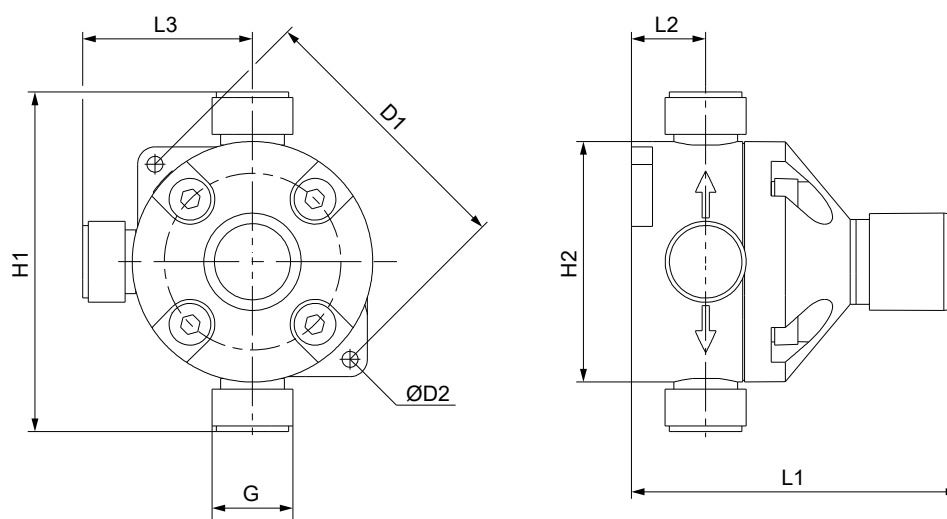

TM087164

#### Pressure-relief valve

Material	L1 in (mm)	L2 in (mm)	L3 in (mm)	H1 in (mm)	H2 in (mm)	D1 in (mm)	ØD2 in (mm)	G
PP / PVC / PVDF	82	21	48	96	68	78	4.5	G5/8
Stainless steel	82	22	20	40	68	-	-	-

### Technical data

Max. flow rate [l/h]	Material			Product number	
	Diaphragm	Body and connections	Gasket	Relief pressure 10 bar	Relief pressure 16 bar
60	PTFE	PP	FKM / EPDM	95730757	95730773
		PVC	FKM / EPDM	95730758	95730774
			PTFE	95730759	95730775
		PVDF	FKM / EPDM	95730760	95730776
			PTFE	95730761	95730777
		Stainless steel	No gaskets	95730771	95730783

### Pressure-loading valves PLV

Pressure-loading valves are installed in the discharge line after the pressure-relief valve, and after the pulsation damper, if fitted.

- Loading pressure, adjustable from 1 to 5 bar, is factory-set to 3 bar.
- Maximum operating pressure: 16 bar.
- Hose connection set: 4/6 mm, 6/9 mm, 6/12 mm, and 9/12 mm.
- Pipe connection set: threaded, Rp 1/4", internal thread (stainless steel).

### Dimensions

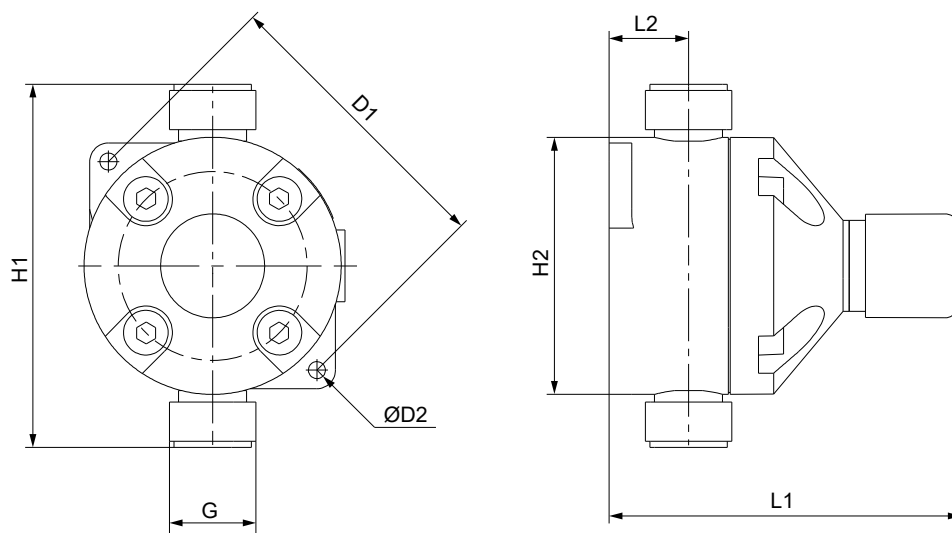

TM087163

### Pressure-loading valve

Material	L1 in (mm)	L2 in (mm)	H1 in (mm)	H2 in (mm)	D1 in (mm)	ØD2 in (mm)	G
PP / PVC / PVDF	82	21	96	68	78	4.5	G5/8
Stainless steel	82	22	40	68	-	-	-

### Technical data

Max. flow rate [l/h]	Material			Product number
	Diaphragm	Body and connections	Gasket	
60	PTFE	PP	FKM / EPDM	95730741
		PVC	FKM / EPDM	95730742
			PTFE	95730743
		PVDF	FKM / EPDM	95730744
			PTFE	95730745
		Stainless steel	No gaskets	95730751

### Pressure valves

Pressure valves provide a constant counterpressure of 3 bar. They are particularly required for DDA FCM-C pumps at very small flow rates.

Pressure valves are installed either directly on the pump discharge side, or on the pressure-relief valve.

- Loading pressure: 3 bar, not adjustable.
- Maximum system pressure: 16 bar.
- Spring material: Alloy C-4 (NiMo16CrTi, material number 2.4610).
- No connections included.

### Dimensions

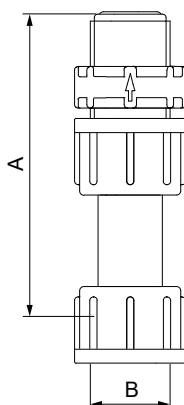

TM069796

Pressure valve

A in (mm)	B
87	G 5/8

### Technical data

Max. flow rate [l/h]	Material			Product number
	Ball	Body	Gaskets	
60	Ceramic	PP	FKM	95730325
			EPDM	95730326
		PVC	FKM	95730327
			EPDM	95730328
			PTFE	95730329
		PVDF	FKM	95730330
	EPDM		95730331	
	PTFE		95730332	
	Stainless steel	Stainless steel	PTFE	95730333

## Pump connection kits and inlay kits

Retrofit pump connection kits and inlay kits are available for the integration of Grundfos standard dosing pumps into installations with various sizes of hoses or pipes.

A pump connection kit includes the following:

- 1 set of inlays
- 1 union nut.

The inlay kits are used for connecting pumps and accessories to pipes or hoses that differ from Grundfos standard sizes.

An inlay kit includes the following:

- 2 sets of inlays.



TM048294



TM048295

Left: pump connection kit; right: inlay kit

### Technical data

Connection type	Size	Material	Product number	
			Connection kit	Inlay kit
Hose (cone and ring)	4/6 mm, 6/9 mm, 6/12 mm, 9/12 mm	PP	97691902	-
		PVC	97691903	-
		PVDF	97691904	-
	0.17" × 1/4", 1/4" × 3/8", 3/8" × 1/2"	PP	97691905	-
		PVC	97691906	-
		PVDF	97691907	-

Connection type	Size	Material	Product number		
			Connection kit	Inlay kit	
Hose (cone and ring)	4/6 mm, or 0.17" x 1/4"	PP	97702474	95730984	
		PVC	97702485	95730720	
		PVDF	97702495	95730729	
	4/9 mm	PP	98153922	98153977	
		PVC	98153944	98154006	
		PVDF	98153949	98154029	
	5/8 mm	PP	97702475	95730711	
		PVC	97702486	95730721	
		PVDF	97702496	95730730	
	6/8 mm	PP	97702476	95730712	
		PVC	97702487	95730722	
		PVDF	97702497	95730731	
	6/9 mm	PP	97702477	95730713	
		PVC	97702488	95730723	
		PVDF	97702498	95730732	
	6/12 mm	PP	97702478	95730714	
		PVC	97702489	95730724	
		PVDF	97702499	95730733	
	9/12 mm	PP	97702479	95730715	
		PVC	97702490	95730725	
		PVDF	97702500	95730734	
	1/4" x 3/8	PP	97702482	95730718	
		PVC	97702492	95730727	
		PVDF	97702503	95730737	
	3/8" x 1/2"	PP	97702483	95730719	
		PVC	97702493	95730728	
		PVDF	97702504	95730738	
	Hose (cutting ring type)	1/8" x 1/4"	PP	97702481	95730717
			PVDF	97702502	95730736
	Pipe welding	External diameter 16 mm	PP	97702480	95730716
PVDF			97702501	95730735	
Pipe welding	Internal diameter 12 mm	PVC	97702491	95730726	
		PVDF	93124556	-	
Pipe, external thread	1/2" NPT	PP	97702484	-	
		PVC	97702494	-	
Pipe, internal thread	Rp 1/4"	PVDF	97702505	-	
		Stainless steel	97702508	-	
Pipe (cutting ring type)	4/6 mm	Stainless steel	97702472	95730739	
		Stainless steel	97702473	95730740	
Pipe (cutting ring type)	8/10 mm	Stainless steel	97702506	-	
		Stainless steel	97702507	-	

## Adapters

### Threaded adapters

Threaded adapters are used for converting between different threaded connection sizes.

A threaded adapter kit includes the following:

- 1 adapter
- 1 O-ring.

### Technical data

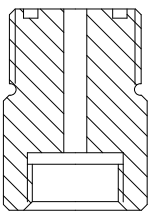
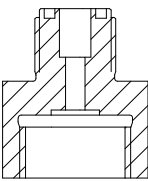
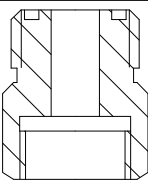
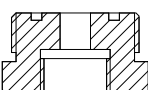
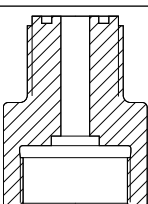
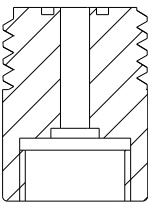
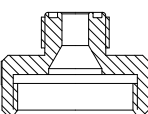
Type	Threaded connection size		Material		Product number
	Internal thread	External thread	Body	Gaskets	
	G 3/8"	G 5/8"	PP	FKM / EPDM	95730407
			PVC	FKM / EPDM	95730408
				PTFE	95730409
			PVDF	FKM / EPDM	95730410
				PTFE	95730411
	G 5/8"	G 3/8"	PP	FKM / EPDM	95730412
			PVC	FKM / EPDM	95730413
				PTFE	95730414
			PVDF	FKM / EPDM	95730415
				PTFE	95730416
	G 5/8"	G 3/4"	PP	FKM / EPDM	95730417
			PVC	FKM / EPDM	95730418
				PTFE	95730419
			PVDF	FKM / EPDM	95730420
				PTFE	95730421
	G 5/8"	G 1 1/4"	PP	FKM / EPDM	95730422
			PVC	FKM / EPDM	95730423
				PTFE	95730424
			PVDF	FKM / EPDM	95730425
				PTFE	95730426
	G 5/8"	M 20 x 1.5	PP	FKM / EPDM	95730427
			PVC	FKM / EPDM	95730428
				PTFE	95730429
			PVDF	FKM / EPDM	95730430
				PTFE	95730431
	G 5/8"	M 30 x 3.5	PVDF	FKM / EPDM	98154048
				PTFE	98154054
	G 1 1/4"	G 5/8"	PP	FKM / EPDM	95730432
			PVC	FKM / EPDM	95730433
				PTFE	95730434
			PVDF	FKM / EPDM	95730435
				PTFE	95730436

### Union nut adapters

Union nut adapters consist of a rigid pipe with union nuts on both ends. They have neither gaskets nor glued or welded connections.

#### Technical data

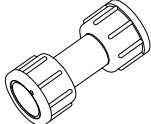
Type	Threaded connection size		Material	Product number
	Internal thread	Internal thread	Body	
	G 5/8"	G 5/8"	PVC	95730437
			PP	95730438
			PVDF	95730439

### Hose-to-hose and hose-to-pipe adapters

#### Technical data

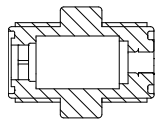
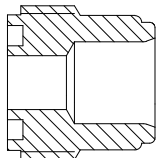
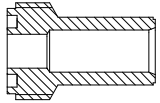
Type	Description	Connections		Material		Product number	
		Side 1	Side 2	Body and connections	Gaskets		
	Valve body with two external threads G 5/8"	For hoses 4/6 mm, 6/9 mm, 6/12 mm, 9/12 mm		PP	FKM / EPDM	95730367	
				PVC	FKM / EPDM	95730368	
					PTFE	95730369	
				PVDF	FKM / EPDM	95730370	
					PTFE	95730371	
				Without	PP	FKM / EPDM	95730356
		PVC	FKM / EPDM		95730357		
			PTFE		95730358		
		PVDF	FKM / EPDM		95730359		
				Without	Threaded Rp 1/4	Stainless steel	PTFE
	Pipe cementing end on one side, external thread G 5/8" on the other side	For hoses 4/6 mm, 6/9 mm, 6/12 mm, 9/12 mm	Internal Ø12 mm	PVC	FKM / EPDM	95730378	
					PTFE	95730379	
		Without	Internal Ø12 mm	PVC	FKM / EPDM	95730365	
					PTFE	95730366	
	Pipe welding end on one side, external thread G 5/8" on the other side	For hoses 4/6 mm, 6/9 mm, 6/12 mm, 9/12 mm	External Ø16 mm	PP	FKM / EPDM	95730377	
				PVDF	FKM / EPDM	95730380	
					PTFE	95730381	
		Without	External Ø16 mm	PVDF	PP	FKM / EPDM	95730362
					FKM / EPDM	95730363	
						PTFE	95730364

## T-pieces

### Technical data

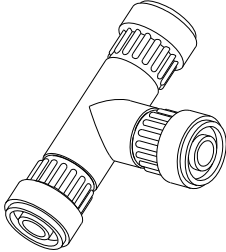
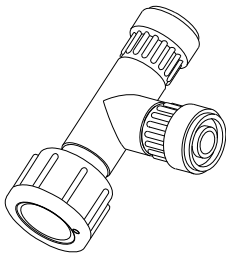
Type	Description	Connections			Material		Product number
		Bottom	Top	Side	Body and connections	Gaskets	
	Three external threads G 5/8"	For hoses 4/6 mm, 6/9 mm, 6/12 mm, 9/12 mm			PP	FKM / EPDM	95730387
					PVC	FKM / EPDM	95730388
						PTFE	95730389
					PVDF	FKM / EPDM	95730390
						PTFE	95730391
					PP	FKM / EPDM	95730346
		Without	PVC	FKM / EPDM	95730347		
				PTFE	95730348		
			PVDF	FKM / EPDM	95730349		
				PTFE	95730350		
	Two male threads G 5/8", one internal connection with union nut	Union nut G 5/8"	Without	For hoses 4/6 mm, 6/9 mm, 6/12 mm, 9/12 mm	PP	FKM / EPDM	95730397
					PVC	FKM / EPDM	95730398
						PTFE	95730399
					PVDF	FKM / EPDM	95730400
						PTFE	95730401
					PP	FKM / EPDM	95730351
		Without	PVC	FKM / EPDM	95730352		
				PTFE	95730353		
			PVDF	FKM / EPDM	95730354		
				PTFE	95730355		

## Dosing tanks

### Square tank, 100 litres

The closed square tank has a screw cap and a mounting platform for one pump or two pumps in parallel.

The pump mounting platform is higher than the screw cap to protect pumps and connections when filling chemicals into the tank.

Characteristics of the tank:

- tank material: MDPE
- weight: 15 kg
- wall thickness: 4 mm
- liquid temperature: -20 °C to +45 °C.

SMART Digital S pumps can be fitted directly on the mounting platform by brass inserts moulded into the platform. For other pumps, a bracket is required.

The square tank is prepared for a G 3/4" drain valve.

When using a rigid suction lance in the tank, choose the counter nut for fixing, see section Adapters for containers.



TM048307

*Square tank*

### Related information

[Adapters for containers](#)

Dimensions

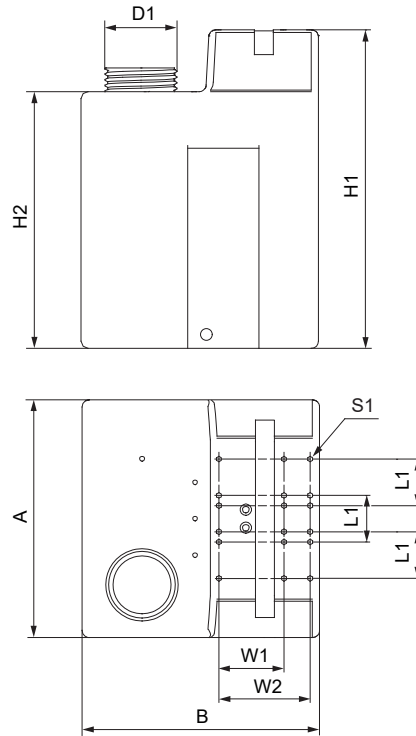

TM069772

Square tank, dimensions

H1 [mm]	H2 [mm]	D1 [mm]	A [mm]	B [mm]	L1 [mm]	W1 [mm]	W2 [mm]	S1
670	540	∅152	500	500	98	137	192	M 5

Order data

Tank volume [l]	Product number
100	96489271

## Cylindrical tanks

Dosing tanks are intended for storing and dosing liquids. Different tank accessories can be mounted directly to the tank. Cylindrical tanks are available in transparent or black. They have a litre scale and a black screw cap.

Characteristics of the tank:

- Tank volume: 40-1000 l
- tank material: LLDPE, UV-stabilised
- liquid temperature: -20 °C to +45 °C.

All cylindrical tanks are prepared for a G 3/4 opening for a drain valve, and have a screw plug (PE or EPDM).

The cylindrical tanks with volumes of 60, 100, 200, 300 and 500 litres additionally include the following:

- threaded M 6 inserts for the direct assembly of a dosing pump
- G 2 opening for a rigid suction lance or a foot valve, closed with a screw plug
- threaded M 6 inserts at the bottom part for floor mounting with a set of floor-mounting brackets
- flange for an electric stirrer with threaded inserts.

The cylindrical tanks with volumes of 60, 100, 200, 300, 500 and 1000 litres can optionally be prepared for direct assembly of an electric stirrer:

- with opening for electric stirrer (60-500 l)
- with opening and reinforced beam for holding an electric stirrer (1000 l).



*Cylindrical tank, 60 litres*

TM048468

### Dimensions of cylindrical tank, 40 litres

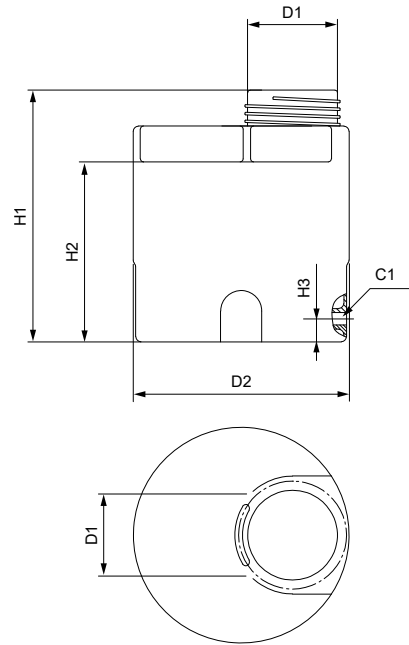

TM069773

H1 [mm]	H2 [mm]	H3 [mm]	D1 [mm]	D2 [mm]	C1
420	350	45	Ø160	Ø420	Rp 3/4

Dimensions of cylindrical tank, 60 and 100 litres

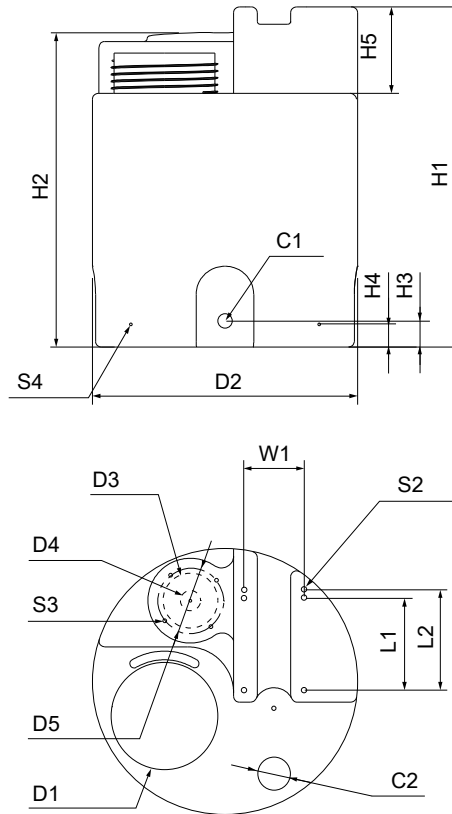

TM069774

Tank volume: 60 l				Tank volume: 100 l			
H1 [mm]		H2 [mm]		H1 [mm]		H2 [mm]	
590		545		840		795	
H3 [mm]	H4 [mm]	H5 [mm]	D1 [mm]	D2 [mm]	D3 [mm]	D4 [mm]	D5 [mm]
50	40	150	∅160	∅460	∅95	∅35	∅130
C1	C2	L1 [mm]	L2 [mm]	W1 [mm]	S2	S3	S4
G 3/4	G 2	159	174	105	M 6 × 9	M 8 × 12	M 6 × 9

Dimensions of cylindrical tank, 200 and 300 litres

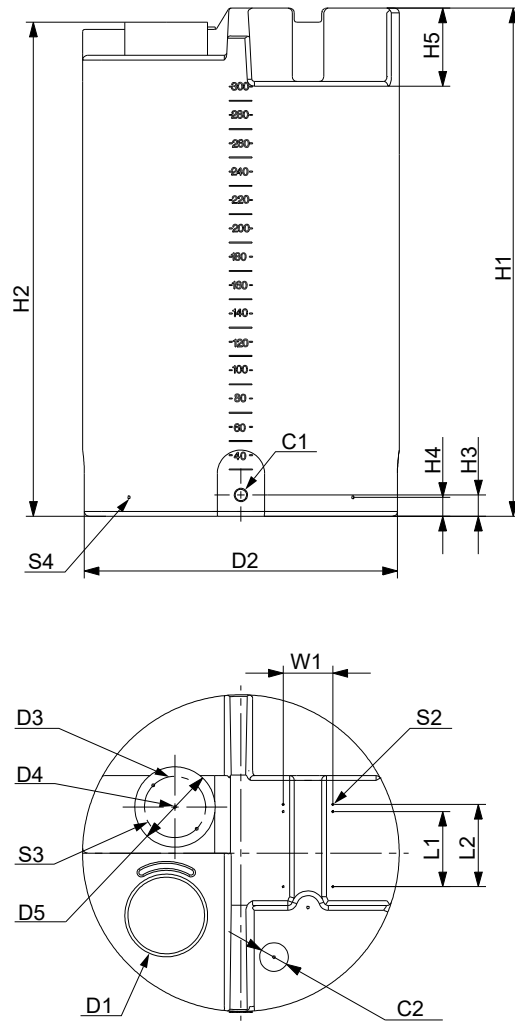

TM086236

Tank volume: 200 l				Tank volume: 300 l			
H1 [mm]		H2 [mm]		H1 [mm]		H2 [mm]	
810		770		1080		1040	
H3 [mm]	H4 [mm]	H5 [mm]	D1 [mm]	D2 [mm]	D3 [mm]	D4 [mm]	D5 [mm]
50	40	150	∅160	∅670	∅115	∅35	∅130
C1 [mm]	C2	L1 [mm]	L2 [mm]	W1 [mm]	S2	S3	S4
G 3/4	G 2	159	174	105	M 6 × 9	M 8 × 12	M 6 × 9

Dimensions of cylindrical tank, 500 litres

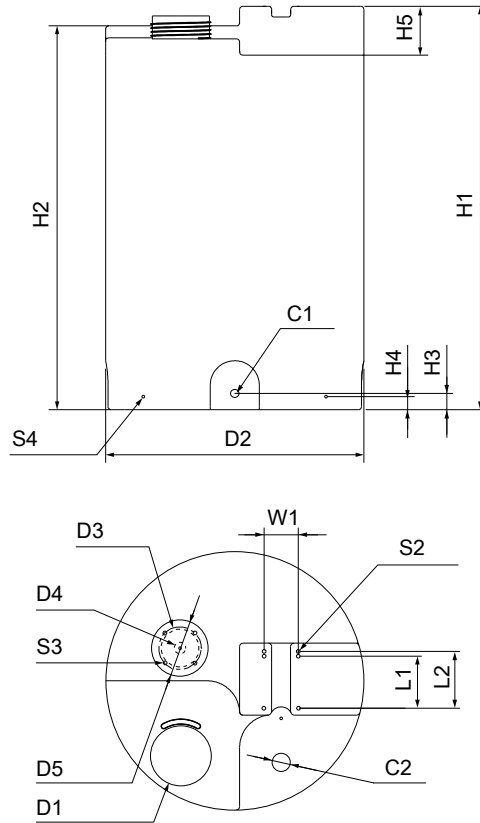

TM069776

H1 [mm]	H2 [mm]	H3 [mm]	H4 [mm]	H5 [mm]	D1 [mm]	D2 [mm]	D3 [mm]	D4 [mm]	D5 [mm]
1235	1175	50	40	150	∅160	∅790	∅115	∅35	∅130
C1	C2	L1 [mm]	L2 [mm]	W1 [mm]	S2	S3	S4		
G 3/4	G 2	159	174	105	M 6 × 9	M 8 × 12	M 6 × 9		

## Dimensions of cylindrical tank, 1000 litres

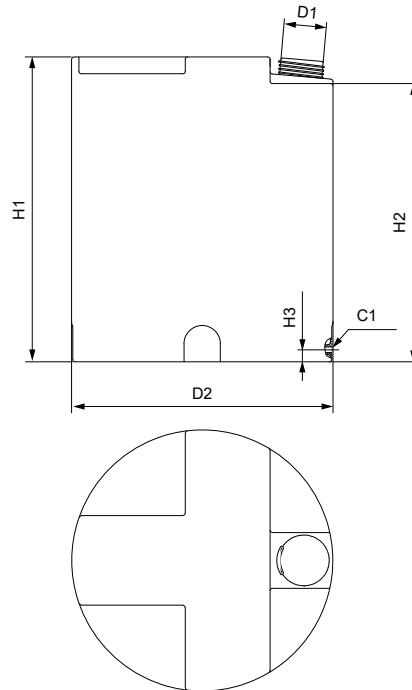

TM069777

H1 [mm]	H2 [mm]	H3 [mm]	D1 [mm]	D2 [mm]	C1
1260	1150	50	∅160	∅1080	G 3/4

## Technical data

Tank volume [l]	Prepared for direct assembly of an electric stirrer	Weight [kg]	Product number	
			Transparent	Black
40	-	3.4	96688081	95701166
60	-	5.5	98148805	98149053
	Yes	5.5	98150038	98150040
100	-	7.5	98149057	98149082
	Yes	7.5	98150051	98150052
200	-	11.5	98149215	98149224
	Yes	11.5	98150053	98150054
300	-	13	98149245	98149252
	Yes	13	98150055	98150056
500	-	28	98149266	98149269
	Yes	28	98150057	98150058
1000	-	40	96688086	95706305
	Yes	48	98173675	98173752

## Related information

[Accessories for dosing tanks](#)

### Collecting tray

The collecting tray is available in several sizes to suit the respective dosing tank size. It collects chemicals that might leak out of the tank, and protects the environment.

- Material: PE.
- Colour: transparent.



TM048316

Collecting tray

For tank size [l]	Volume [l]	Dimensions (diameter × height) [mm]	Product number
60	80	500 × 545	96726831
100	120	500 × 700	96726832
200	210	770 × 595	98150059
300	400	770 × 960	96726834
500	500	860 × 980	95701272
1000	1000	1150 × 1080	96726836

### Accessories for dosing tanks

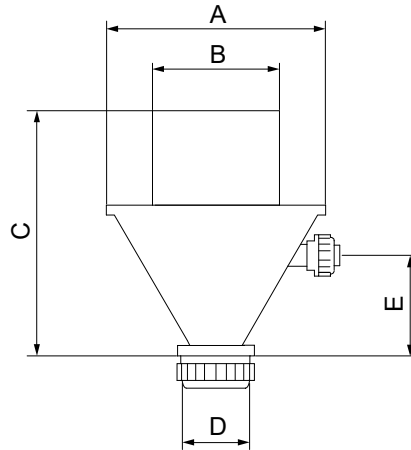

TM069778

Dissolving hopper, dimensions

A [mm]	B [mm]	C [mm]	D [mm]	E [mm]
∅270	∅140	283	∅70	120

### Technical data

Description	Specifications	Material	Product number
Drain valve for installation in the threaded sleeve of the dosing tank	Dosing tank connection G 3/4"	PVC	96689132
Ventilation valve	Spring-loaded, opening pressure 0.05 bar	PVC / FKM / glass	96694401
Dissolving hopper for washing powders into the dosing tank	Dosing tank connection: DN 40 through-bolt Water connection: G 5/4", with union nut and inlay for PVC pipe (cementing diameter 25 mm)	PVC	96726979
Handheld mixer for use in dosing tanks	Shaft length 1200 mm, length can be adapted to the corresponding dosing tank with DN 15 through-bolt for connection at the dosing tank	PE	98133793
Set of floor-mounting brackets	4 floor-mounting brackets with fixing screws		98149921
Set of screws for mounting a pump on a 100-litre square tank	For pump types DDA-C, DDC, DDE	Stainless steel	95730862
Set of screws for mounting a pump on a 60-, 100-, 200-, 300-, or a 500-litre cylindrical tank	For pump types DDA-C, DDC, DDE, DMX model 221	Stainless steel	98159495
Set of screws for mounting a pump on a 40-litre or a 1000-litre cylindrical tank	For pump types DDA-C, DDC, DDE, DMX model 221	PP	95730864



TM087077

Drain valve for installation in the threaded sleeve of the dosing tank



TM087078

Ventilation valve



Set of floor-mounting brackets

TM087079



Handheld mixer

TM048477

## Water meter

The in-line water meter with potential-free pulse signal is suitable for use in flow-proportional dosing applications.

- Qn 1.5 and Qn 2.5 meters are of the multi-jet, dry dial type, for cold water up to 30 °C, or hot water up to 90 °C.
- Qn 15 meters and up are of the helical vane type, for cold water up to 50 °C, or hot water up to 120 °C.
- Max. pressure: 16 bar.

If the water meter is connected directly to the pump pulse input, use a control plug (PN 96698715).

- Qn 1.5 to Qn 15 meters are threaded.
- Qn 40 to Qn 150 meters are flanged.
- Cable length: 3 m.



TM048317

### Water meter

Qn [m <sup>3</sup> /h]	Pulse rate [l/pulse]	Maximum short- period capacity [m <sup>3</sup> /h]	Max. pressure [bar]	Transitional capacity with error ± 2 % [l/h]	Minimum capacity with error ± 5 % [l/h]	Product number			
						Maximum water temperature			
						30 °C	50 °C	90 °C	120 °C
1.5 <sup>43)</sup>	1	3	16	120	50	96446846	-	96446897	-
2.5 <sup>43)</sup>	2.5	5	16	200	70	96446847	-	96446898	-
15 <sup>43)</sup>	10	30	16	3000	450	-	96446848	-	96446899
1.5 <sup>43)</sup>	0.25	3	16	120	50	96482640	-	96482643	-
2.5 <sup>43)</sup>	0.25	5	16	200	70	96482641	-	96482644	-
15 <sup>43)</sup>	2.5	30	16	3000	450	96482642	-	96482645	-
40 <sup>44)</sup>	100	80	10	4000	700	-	96446849	-	96446900
60 <sup>44)</sup>	25	120	10	6000	1200	-	96446850	-	96446901
150 <sup>44)</sup>	100	300	10	12000	3000	-	96446851	-	96446902

<sup>43)</sup> Maximum load, Reed contact: 30 VAC/VDC, 0.2 A

<sup>44)</sup> Maximum load, Namur contact: 8-12 VDC, 1 kOhm (requires external power supply)

### Dimensions

Size	Connections	Installation kit connection	Port-to-port length [mm]	Port-to-port length incl. kit [mm]
Threaded connection				
Qn 1.5	G 3/4"	G 1/2"	165	245
Qn 2.5	G 1"	G 3/4"	190	288
Qn 15	G 2.5	G 2"	300	438
Flanged connection				
Qn 40	DN 80		225	-
Qn 60	DN 100		250	-
Qn 150	DN 150		300	-

## 9. Pumped liquids

The resistance table below is intended as a general guide for material resistance (at room temperature), and does not replace testing of the chemicals and pump materials under specific working conditions.

The data shown are based on information from various sources available, but many factors, such as purity, temperature, abrasive particles, may affect the chemical resistance of a given material.

Some of the liquids in this table may be toxic, corrosive or hazardous. Be careful when handling these liquids.

● = Resistant

○ = Limitedly resistant

- = Not resistant

Pumped liquid (20 °C)			Material								
			Dosing head			Gasket			Ball		
Description	Chemical formula	Concentration %	PP	PVDF	SS 1.4435	PVC	FKM	EPDM	PTFE	Ceramic	PE (Accessories)
Acetic acid	CH <sub>3</sub> COOH	25	●	●	●	●	-	●	●	●	●
		60	●	●	●	●	-	●	●	●	●
		85	●	●	○	-	-	-	●	●	-
Aluminium chloride	AlCl <sub>3</sub>	40	●	●	-	●	●	●	●	●	●
Aluminium sulphate	Al <sub>2</sub> (SO <sub>4</sub> ) <sub>3</sub>	60	●	●	●	●	●	●	●	●	●
Ammonia, aqueous	NH <sub>4</sub> OH	28	●	-	●	●	-	●	●	●	●
Calcium hydroxide <sup>45)</sup>	Ca(OH) <sub>2</sub>		●	●	●	●	●	●	●	●	●
Calcium hypochlorite	Ca(OCl) <sub>2</sub>	20	○	●	-	●	●	●	●	●	●
Chlorine dioxide	ClO <sub>2</sub>	3	-	●	-	●	●	-	●	●	-
Chromic acid	H <sub>2</sub> CrO <sub>4</sub>	10	●	●	●	●	●	●	●	●	●
		30	-	●	-	●	●	○	●	●	●
		50	-	●	-	●	●	-	●	●	●
Copper sulphate	CuSO <sub>4</sub>	30	●	●	●	●	●	●	●	●	●
Ferric chloride <sup>46)</sup>	FeCl <sub>3</sub>	60	●	●	-	●	●	●	●	●	●
Ferric sulphate <sup>46)</sup>	Fe <sub>2</sub> (SO <sub>4</sub> ) <sub>3</sub>	60	●	●	○	●	●	●	●	●	●
Ferrous chloride	FeCl <sub>2</sub>	40	●	●	-	●	●	●	●	●	●
Ferrous sulphate	FeSO <sub>4</sub>	50	●	●	●	●	●	●	●	●	●
Fluosilicic acid	H <sub>2</sub> SiF <sub>6</sub>	40	●	●	○	●	-	○	●	●	●
Hydrochloric acid	HCl	< 25	●	●	-	●	●	●	●	●	●
		25-37	●	●	-	●	●	○	●	●	●
Hydrogen peroxide	H <sub>2</sub> O <sub>2</sub>	30	●	●	●	●	●	●	●	●	●
		30	●	●	●	●	●	●	●	●	●
Nitric acid	HNO <sub>3</sub>	40	○	●	●	●	●	-	●	●	●
		70	-	●	●	-	●	-	●	●	○
Peracetic acid	CH <sub>3</sub> COOOH	5-15	○	●	○	○	-	-	●	●	○
Potassium hydroxide	KOH	50	●	-	●	●	-	●	●	●	●
Potassium permanganate	KMnO <sub>4</sub>	10	●	●	●	●	○	●	●	●	●
Sodium chlorate	NaClO <sub>3</sub>	30	●	●	●	●	●	●	●	●	●
Sodium chloride	NaCl	30	●	●	-	●	●	●	●	●	●
Sodium chlorite	NaClO <sub>2</sub>	20	●	●	-	○	●	●	●	●	●
		30	●	●	●	●	○	●	●	●	●
Sodium hydroxide	NaOH	50	●	●	●	●	-	●	●	●	●
Sodium hypochlorite (commercial)	NaClO	12-15	-	●	-	●	●	●	●	●	●
Sodium hypochlorite (produced by electrolysis system)	NaClO	0,8	-	●	-	-	●	●	●	●	○
Sodium sulphide	Na <sub>2</sub> S	30	●	●	●	●	●	●	●	●	●
Sodium sulphite	Na <sub>2</sub> SO <sub>3</sub>	20	●	●	●	●	●	●	●	●	●
Sodium thiosulfate	Na <sub>2</sub> S <sub>2</sub> O <sub>3</sub>	10	●	●	●	●	●	●	●	●	●

Pumped liquid (20 °C)			Material								
Description	Chemical formula	Concentration %	Dosing head			Gasket			Ball		PE (Accessories)
			PP	PVDF	SS 1.4435	PVC	FKM	EPDM	PTFE	Ceramic	
Sulphurous acid	H <sub>2</sub> SO <sub>3</sub>	6	•	•	•	•	•	•	•	•	•
		< 80	•	•	-	•	•	○	•	•	•
Sulphuric acid <sup>47)</sup>	H <sub>2</sub> SO <sub>4</sub>	80-96	○	•	-	•	•	-	•	•	-
		98	-	•	•	-	○	-	•	•	-

45) Once the pump stops, calcium hydroxide sediments rapidly.

46) There is risk of crystallisation.

47) It reacts violently with water and generates much heat. (The pump should be absolutely dry before dosing Sulphuric acid.)

Further information:

<https://product-selection.grundfos.com/pumped-liquid-guide>

## 10. Grundfos Product Center

Online search and sizing tool to help you make the right choice.

From the international view, you can select your specific country to view the product range available to you.

International view: <https://product-selection.grundfos.com>

### All the information you need in one place

Performance curves, technical specifications, pictures, dimensional drawings, motor curves, wiring diagrams, spare parts, service kits, 3D drawings, documents, system parts. The Product Center displays any recent and saved items - including complete projects - right on the main page.

### Downloads

On the product pages, you can download installation and operating instructions, data booklets, service instructions, etc., in PDF format.

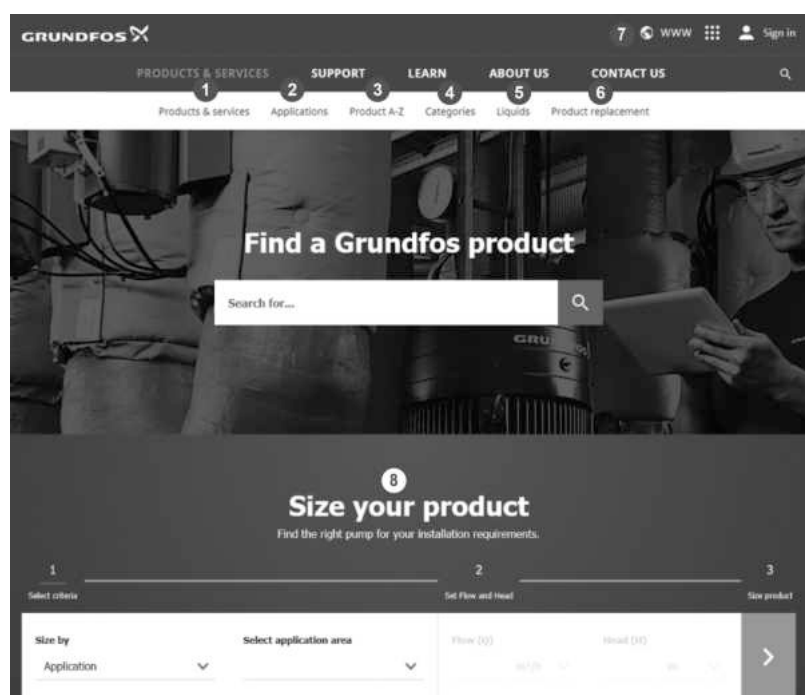

When you select your country, you will see the menus below. Note that some menus may not be available depending on the country.

Example: <https://product-selection.grundfos.com/uk>

Pos.	Description
1	<b>Products &amp; services</b> enables you to find products and documents by typing a product number or name into the search field.
2	<b>Applications</b> enables you to choose an application to see how Grundfos can help you design and optimise your system.
3	<b>Products A-Z</b> enables you to look through a list of all the Grundfos products.
4	<b>Categories</b> enables you to look for a product category.
5	<b>Liquids</b> enables you to find pumps designed for aggressive, flammable or other special liquids.
6	<b>Product replacement</b> enables you to find a suitable replacement.
7	<b>WWW</b> enables you to select the country, which changes the language, the available product range and the structure of the website.
8	<b>Sizing</b> enables you to size a product based on your application and operating conditions.

## 11. Document quality feedback

To provide feedback about this document, scan the QR code using your phone's camera or a QR code app.



[Click here to submit your feedback](#)

FEEDBACK93113954

93113954 09.2024

ECM: 1386291

**GRUNDFOS Holding A/S**  
Poul Due Jensens Vej 7  
DK-8850 Bjerringbro  
Tel: +45 87 50 14 00  
[www.grundfos.com](http://www.grundfos.com)

**GRUNDFOS** 